

Anticipatory Systems

Volume 1

International Federation for Systems Research International Series on Systems Science and Engineering

Series Editor: George J. Klir
Binghamton State University

Editorial Board

Gerrit Broekstra
*Erasmus University, Rotterdam,
The Netherlands*

John L. Castii
Sante Fe Institute, New Mexico

Brian Gaines
University of Calgary, Canada

Ivan M. Havel
*Charles University, Prague,
Czech Republic*
Klaus Kornwachs
*Technical University of Cottbus,
Germany*
Franz Pichler
University of Linz Austria

- Volume 22 *ORGANIZATION STRUCTURE: Cybernetic Systems Foundation*
Yasuhiko Takahara and Mihajlo Mesarovic
- Volume 23 *CONSTRAINT THEORY: Multidimensional Mathematical Model Management*
George J. Friedman
- Volume 24 *FOUNDATIONS AND APPLICATIONS OF MIS: Model Theory Approach*
Yasuhiko Takahara and Yongmei Liu
- Volume 25 *GENERALIZED MEASURE THEORY*
Zhenyuan Wang and George J. Klir
- Volume 26 *A MISSING LINK IN CYBERNETICS: Logic and Continuity*
Alex M. Andrew
- Volume 27 *SEMANTICS-ORIENTED NATURAL LANGUAGE PROCESSING: Mathematical Models and Algorithms*
Vladimir A. Fomichov

IFSR was established "to stimulate all activities associated with the scientific study of systems and to coordinate such activities at international level." The aim of this series is to stimulate publication of high-quality monographs and textbooks on various topics of systems science and engineering. This series complements the Federation's other publications.

A Continuation Order Plan is available for this series. A continuation order will bring delivery of each new volume immediately upon publication. Volumes are billed only upon actual shipment. For further information please contact the publisher.

Volumes 1–6 were published by Pergamon Press

Robert Rosen

Anticipatory Systems

Philosophical, Mathematical,
and Methodological Foundations

Second Edition

With Contributions by Judith Rosen, John J. Kineman,
and Mihai Nadin

 Springer

Robert Rosen
(Deceased)

Series Editor:

George J. Klir
Thomas J. Watson School of Engineering and Applied Sciences
Department of Systems Science and Industrial Engineering
Binghamton University
Binghamton, NY 13902
U.S.A.

Addendum 1: Autobiographical Reminiscences

© Judith Rosen

ISSN 1574-0463

ISBN 978-1-4614-1268-7 e-ISBN 978-1-4614-1269-4

DOI 10.1007/978-1-4614-1269-4

Springer New York Dordrecht Heidelberg London

Library of Congress Control Number: 2011942919

© Judith Rosen 2012

All rights reserved. This work may not be translated or copied in whole or in part without the written permission of the publisher (Springer Science+Business Media, LLC, 233 Spring Street, New York, NY 10013, USA), except for brief excerpts in connection with reviews or scholarly analysis. Use in connection with any form of information storage and retrieval, electronic adaptation, computer software, or by similar or dissimilar methodology now known or hereafter developed is forbidden.

The use in this publication of trade names, trademarks, service marks, and similar terms, even if they are not identified as such, is not to be taken as an expression of opinion as to whether or not they are subject to proprietary rights.

Printed on acid-free paper

Springer is part of Springer Science+Business Media (www.springer.com)

Foreword

This manuscript was written during the months between January and June in 1979. The writing was done under difficult circumstances. At that time, I had some reason to fear that I would no longer be able to personally pursue a program of active scientific research. Yet at the time, I felt (and still do) that I had arrived upon the threshold of some entirely new perspectives in the theory of natural systems, and of biological systems in particular. The issues involved were of sufficient interest and importance for me to wish them to be pursued by others, if they so desired. On the other hand, my own outlook and development are different from other people's, and have with justification been called idiosyncratic. Thus I resolved to try, while I knew I was still able, to set down a coherent narrative development, beginning with the most elementary matters, which I hoped would permit others to understand why I was doing the things I was doing.

This volume is the result. I have organized it around the concept of anticipation, which is fundamental in its own right, and which connects naturally to a cluster of other concepts lying at the heart of natural science and of mathematics. Strictly speaking, an anticipatory system is one in which present change of state depends upon future circumstances, rather than merely on the present or past. As such, anticipation has routinely been excluded from any kind of systematic study, on the grounds that it violates the causal foundation on which all of theoretical science must rest, and on the grounds that it introduces a telic element which is scientifically unacceptable. Nevertheless, biology is replete with situations in which organisms can generate and maintain internal predictive models of themselves and their environments, and utilize the predictions of these models about the future for purpose of control in the present. Many of the unique properties of organisms can really be understood only if these internal models are taken into account. Thus, the concept of a system with an internal predictive model seemed to offer a way to study anticipatory systems in a scientifically rigorous way.

This book is about what else one is forced to believe if one grants that certain kinds of systems can behave in an anticipatory fashion. I begin with an autobiographical account of how I came to believe that anticipatory systems were important, and why. I then proceed to an extensive discussion of the central concept

of anticipation, namely, the modeling relation between a system and a model, or a system and an analog. In the process of exploring this relation, and by exhibiting manifold and diverse examples of this relation, I try to establish the basic threads between the concepts of science and mathematics. I hope that this discussion will be of interest in its own right, and will also serve to illustrate that the approaches I take are not really as idiosyncratic as they might at first appear. Only when this background is laid do I turn to the concept of anticipation itself, and explore some of the elementary properties of systems which can anticipate. Here I well realize, the surface is barely scratched. But this was as far as I had been able to progress at the time, and the point of the book is to guide the reader to the surface.

For a variety of external reasons, the manuscript was not published immediately. However, none of the fundamental material has changed in the intervening five years, and I have not altered the original text. I have, however, added an appendix. It has turned out that the initial anxieties which generated the book were unfounded, and since that time, I have been able to push some of the fundamental implications of the relation between system and model much further. In the appendix, some of these more recent developments are sketched, and some of their rather startling implications are pointed out. I hope to enlarge this appendix into a separate monograph in the near future, giving full details to justify what is merely asserted therein.

I would like to take this occasion to thank the many colleagues and friends who have lent precious moral support as a beacon through dark times. Among them I may mention J.F. Danielli, George Klir, I.W. Richardson, Otto Röessler, Ei Teramoto, and Howard Pattee. I hope that this volume will justify at least some small part of their exertions on my behalf over the years.

Robert Rosen

[Note: Judith Rosen would like to add her thanks to Dr. Aloisius Louie for his early help in her efforts to republish this book and to Mr. Pete Giansante, for his assistance and encouragement towards that goal, as well. An enormous debt of gratitude is owed to Dr. George Klir, who once again was instrumental in helping to ensure that this work is made accessible and will now remain so for posterity.]

Preface to the First Edition

The present volume is intended as a contribution to the theory of those systems which contain internal predictive models of themselves and/or of their environment, and which utilize the predictions of their models to control their present behavior.

Systems of this type have a variety of properties which are unique to them, just as “closed-loop” systems have properties which make them different from “open-loop” systems. It is most important to understand these properties, for many reasons. We shall argue that much, if not most, biological behavior is model-based in this sense. This is true at every level, from the molecular to the cellular to the physiological to the behavioral. Moreover, model-based behavior is the essence of social and political activity. An understanding of the characteristics of model-based behavior is thus central to any technology we wish to develop to control such systems, or to modify their model-based behavior in new ways.

The essential novelty in our approach is that we consider such systems as single entities, and relate their overall properties to the character of the models they contain. There have, of course, been many approaches to planning, forecasting, and decision-making, but these tend to concentrate on tactical aspects of model synthesis and model deployment in specific circumstances; they do not deal with the behavioral correlates arising throughout a system simply from the fact that present behavior is generated in terms of a predicted future situation. For this reason, we shall not at all be concerned with tactical aspects of this type; we do not consider, for instance, the various procedures of extrapolation and correlation which dominate much of the literature concerned with decision-making in an uncertain or incompletely defined environment. We are concerned rather with global properties of model-based behavior, irrespective of how the model is generated, or indeed of whether it is a “good” model or not.

From the very outset, we shall find that the study of such global aspects of model-based behavior raises new questions of a basic epistemological character. Indeed, we shall see that the utilization of predictive models for purposes of present control confront us with problems relating to causality. It has long been axiomatic that system behavior in the present must never depend upon future states or future inputs; systems which violate this basic axiom are collectively called *anticipatory*, and are

routinely excluded from science. On the other hand, the presence of a predictive model serves precisely to pull the future into the present; a system with a “good” model thus behaves in many ways like a true anticipatory system. We must thus reconsider what is meant by an anticipatory system; the suggestion arising from the present work is that model-based behavior requires an entirely new paradigm, which we call an “anticipatory paradigm”, to accommodate it. This paradigm extends (but does not replace) the “reactive paradigm” which has hitherto dominated the study of natural systems, and allows us a glimpse of new and important aspects of system behavior.

The main theoretical questions with which we deal in the present work are the following: (a) What is a model? (b) What is a *predictive* model? (c) How does a system which contains a predictive model differ in its behavior from one which does not? In the process of exploring these questions, starting from first principles, we are led to a re-examination of many basic concepts: time, measurement, language, complexity. Since the modeling relation plays a central role in the discussion, we provide numerous illustrations of it, starting from models arising entirely within symbolic systems (mathematics) through physics, chemistry and biology. Only when the modeling relation is thoroughly clarified can we begin to formulate the basic problems of model-based behavior, and develop some of the properties of systems of the kind with which we are concerned.

It is a pleasure to acknowledge the assistance of many friends and colleagues who have aided me in developing the circle of ideas to be expounded below. A primary debt is owed to my teacher, Nicolas Rashevsky, who above all set an example of fearlessness in entering territory which others thought forbidden. An equally important debt is owed to Robert Hutchins, and to the Center which he created; it was there that I was first forced to confront the nature of anticipatory behavior. A third debt is to my colleagues at the Center for Theoretical Biology: James F. Danielli, Howard Pattee, Narendra Goel, and Martynas Ycas, for their intellectual stimulation and support over the years. Gratitude must also be expressed to Dalhousie University, where thought and the leisure to think are still valued, and especially to my colleague I.W. Richardson.

Robert Rosen

Contents

1 Preliminaries	1
1.1 General Introduction	1
1.2 The Reactive Paradigm: Its Basic Features	22
2 Natural and Formal Systems	45
2.1 The Concept of a Natural System	45
2.2 The Concept of a Formal System	54
2.3 Encodings Between Natural and Formal Systems	71
3 The Modeling Relation	85
3.1 The Modeling Relation within Mathematics	85
3.2 Specific Encodings Between Natural and Formal Systems	119
3.3 Encodings of Physical Systems	130
3.4 Encodings of Biological Systems: Preliminary Remarks	164
3.5 Specific Encodings of Biological Systems	168
3.6 Models, Metaphors and Abstractions	202
4 The Encodings of Time	213
4.1 Time and Dynamics: Introductory Remarks	213
4.2 Time in Newtonian Dynamics	215
4.3 Time in Thermodynamics and Statistical Analysis	223
4.4 Probabilistic Time	231
4.5 Time in General Dynamical Systems	237
4.6 Time and Sequence: Logical Aspects of Time	244
4.7 Similarity and Time	249
4.8 Time and Age	254
5 Open Systems and the Modeling Relation	261
5.1 General Introduction	261
5.2 Open, Closed and Compensated Systems	263
5.3 Compensation and Decompensation	269
5.4 The Main Theorem	272
5.5 Models as Closed Systems	277

5.6	The Concept of Error	283
5.7	Error and Complexity	297
5.8	Order and Disorder	300
5.9	The Stability of Modeling Relations	306
6	Anticipatory Systems	313
6.1	General Introduction	313
6.2	An Example: Forward Activation	320
6.3	General Characteristics of Temporal Spanning	325
6.4	An Application: Senescence	330
6.5	Adaptation, Natural Selection and Evolution	339
6.6	Learning	352
6.7	Selection in Systems and Subsystems	358
6.8	Perspectives for the Future	365
7	Appendix	371
7.1	Prefatory Remarks	371
7.2	Introduction	372
7.3	The Paradigm of Mechanics	376
7.4	Information	380
7.5	An Introduction to Complex Systems	386
8	Relational Science: Towards a Unified Theory of Nature	399
8.1	Introduction	399
8.2	R-Theory	401
8.3	Cause vs. Probability	406
8.4	Context: The Final and Formal Causes	409
8.5	Causal Closure	411
8.6	Modeling Relations	412
8.7	M-R Systems and Anticipation	414
8.8	Organization, Entropy, and Time	416
8.9	Conclusion	418
	Autobiographical Reminiscences	421
	Epilogue	437
	The Devil's Advocate	439
	The Devil's Advocate	441
	Index	469

Preface to the Second Edition: The Nature of Life

What you are holding in your hands is a book about biology. About LIFE. It is a book that describes and elucidates, in scientific terms, the causal forces underlying the unique nature of all living organisms. It presents a set of rigorous and logical interlocking ideas which make clear what is generating the familiar behavior patterns we can observe in ourselves and all around us, everyday, and which characterize “life” as a systemic quality or feature of a system.

Life is Anticipatory

Living organisms have the equivalent of one “foot” in the past, the other in the future, and the whole system hovers, moment by moment, in the present – always on the move, through time. The truth is that *the future* represents as powerful a causal force on current behavior as the past does, for all living things. And information, which is often presumed to be a figment of the human mind or at least unique to the province of human thought and interaction, is actually an integral feature of life, itself – even at the most fundamental level: that of system organization.

These are all findings which are described and elaborated here and, in my opinion, this particular book represents the most important of my father’s scientific discoveries. The development of this aspect of his larger theoretical work on relational complexity (lately being called “Relational Science”) is able to explain what have, heretofore, remained the most baffling and inexplicable of organismic living behaviors. It also demonstrates how and why the clues have been missed by science for so long. The current, purely reactive, paradigm for science is able to do many things but it cannot be expected to help us adequately with problems and questions pertaining to living systems if living systems are not merely reactive. This becomes a critical issue because science represents the set of tools humanity uses for exploring and understanding ourselves, our universe, and our place in the web of life here on Earth. We need to be able to trust our tools to help us solve problems in the biosphere without generating side effects worse than the problems, themselves.

Every living organism comes into being with a system-based value for *health*. Emerging from that value for health is a guiding principle that is equally individual: *optimality*. The functional capabilities of life – metabolism and repair – are entirely guided by these two values. What is clear from the outset is that the values pre-exist the business of living. Perhaps *time* is not quite as linear as we have always presumed it to be. My father’s view, in fact, was that, “Time is complex.”

According to Robert Rosen, the means by which a living system is internally guided and controlled involves encoded information acting as an interactive set of models – of self, of environment, and of relations between the two... through time. These models have the capacity to *predict* next behavior (of self and/or of native environment) based on current behavior. The fact that these are model predictions, as opposed to prescience or prophesy, can be proven by studying the peculiar error behaviors that arise when the encoded information being used in the models no longer accurately represents the systems it was encoded from. For example, if the environment changes, quickly and radically, from the way it has been throughout the recent evolutionary past, the models will no longer be able to reliably predict next behavior of environment from current behavior.

This is what happens when an organism is moved from its native environment and transplanted to some new environment, as in the case of “annual” plants and flowers sold in my neighborhood in Western New York State. Or tropical plants and trees grown indoors in pots, here. Many of these plants are not really annuals, but perennials which can live for many years, sometimes decades and (in the case of trees) centuries. However, they come from environments that never have had a winter like ours, and therefore have no information about it, either. Native plants begin to enter dormancy in mid to late August, here, triggered by various environmental cues such as changing day/night length, but the “annuals” bloom merrily away in pots and in the garden right up until the first freeze kills them outright.

Another proof that these are models can be demonstrated by observing that they can be “fooled.” The horticultural industry uses this situation to very good effect: Producing Easter lilies blooming in time for the Easter market, Poinsettias blooming in time for Christmas, and so on. All that is required to trigger initiation of the bloom cycle is to mimic the behavior of their native environment just prior to their natural bloom time. If we have figured out what the triggers or cues are, we can merely mimic those and achieve our ends. It can be quite specific: day or night length, soil or air temperature, temperature differential between day and night, a period of dryness of a specific length... each organism has its own triggers based on the encoded information in its models. All “instinctive” behavior of living organisms is based on the activity of such internal predictive models, generated from encoded information within their own systemic organization. To observe and learn about the annual migration of Monarch butterflies in North America gives us enough evidence to put us in awe of just how detailed the encoded information can be and how powerful is the guiding action of these internal models on the behavior patterns of all living things.

There are stark dangers embodied in this situation, however, which will become clear as you read this book. The dangers stem from the fact that many of the encoded models (and/or the information from which they are constructed) are either not able to be changed within a single organism's life time or else they change too slowly to be able to avoid disaster in a rapidly changing world. There is no way to know, from within a model, that the system it was encoded from has changed radically. The model will keep on making predictions using wrong information – and the organism will still be guided, partly or entirely, by those predictions. If the predictions are inappropriate, the behavior will similarly be inappropriate – perhaps to the point of mismatches that prove lethal to the organism. Because organism species within an ecosystem are so interlinked in their requirements and dependencies, the death of significant numbers of one species can initiate further rapid changes in the behavior of the local environment, which can ultimately cause rapidly escalating cascades of extinctions.

This is the Achilles heel, the innate vulnerability, of all anticipatory systems. With human-induced changes to the composition of Earth's atmosphere happening at an unprecedented pace over the past two hundred years, and the further unknown changes which are likely to be caused by them, we would do well to pay very careful attention to the warning that is inherent in these facts. Any model-based guidance system will only be as good as the encoded information it uses. If a model is constructed using inaccurate information, its predictions will be unreliable – and this is as true in science as it is in the guided behavior patterns of organisms.

Indeed, because human beings are living organisms, we are also anticipatory systems. The lessons we can learn and apply from this will impact everything. Something as ordinary and commonplace as *how we construct our food pyramid* should be based on what our bodies have encoded as “food”. My hope (my prediction) is that the ramifications of these ideas can expand the paradigm of science itself. The effects of doing so would benefit everything from medical science to psychology, social science, political science, economics – in fact: anything that involves human physiology, human thought and learning, and human interactions with each other or with the biosphere.

The nature of the human mind, in particular, has so far eluded most of the attempts we have made in science to understand it. We seek to comprehend both the nature of our own consciously aware mind and its origins – how it came into being. The final ground-breaking aspect of this book is that it realizes, within the fundamental theory being developed here, that the similarity between life and mind is simply that both are anticipatory systems. The peculiar, anticipatory nature of the mind, at the behavioral and physiological level, was described philosophically a couple thousand years ago (for example, in Buddhist teachings like the Satipathana Sutta) but it has never been explainable via science, until now. Anticipatory Systems Theory elucidates how it can be that both body and mind run on the same principles of model-based guidance and control.

In that light, it becomes clear that the only reason the human mind can anticipate is because life was already *that way*. Thus, the human mind is merely an evolutionary concentration of the same information-sifting, encoding, and model-

building capacities of living system organization. It is a model-building tool that is capable of error-checking and re-encoding faulty models – but in real time versus evolutionary time. The accuracy and speed of an organism’s ability to model and predict would naturally be something that selection pressures could act on. The boon to survival that human intelligence and imagination represents – allowing us to work around all manner of physical limitations in our environments and ourselves – certainly correlates with how overpopulated humanity has become.

However, the recognition in recent years of the need for human societies to be sustainable in order for us to maintain our own health and well-being, over time, brings with it an awareness that there is an acute and urgent need for scientific answers that we can rely on pertaining to biological questions, problems, and issues. When time is short, trial and error is hardly the most efficient or productive mode for sorting out our choices. Because our own welfare is inextricably bound up with the welfare of the biosphere, humanity will need to consider a much larger set of values for optimality than we have ever needed to use in the past. This book will be essential for helping humanity expand the scientific paradigm in such a way that it can finally be trusted to answer biological questions *accurately* and give us scientific models and model predictions that can *reliably help us in choosing the most optimal pathways towards a healthy and sustainable future*.

It is for all these reasons and more that I have worked to get this book republished in the form of an expanded Second Edition. An entire new area of science has already begun to spring up around this work, but without access to the theoretical underpinnings to guide its growth, I fear that it will be prone to develop improperly. I also wanted to include some of the new science, recruiting scientists I know personally who are developing it; allowing them to describe what they are doing and show the applicability of it. The true test of any theory is to put it into practice and see if it holds – see if it generates results and check that the results are beneficial. I think the evidence is conclusive. I leave it to the reader to decide whether I have my own models properly encoded, or not.

If it is true that knowledge is power, then this book is powerful, indeed. Use it wisely, and well.

Judith Rosen

[Note to Readers: Do not be intimidated by the mathematical notation in this book! In discussions with my father on this subject, he said that the mathematics represent *additional illustration of ideas already described in prose*. It was his form of “bullet-proofing” as well as whatever value could be made available to readers from absorbing the same ideas in a different way. I specifically asked him whether one needed to understand the math to fully comprehend the work and he said, “No.” Therefore, if advanced math is something you have not been trained for, concentrate on the prose and ignore the mathematical illustrations. You have Robert Rosen’s own assurances that you will not be missing any essential information by doing so.]

Prolegomena: What Speaks in Favor of an Inquiry into Anticipatory Processes?

Mihai Nadin

The book you hold in your hands is part of a larger intellectual endeavor. It can be read and understood as a stand-alone monograph. Yet to fully realize its predicaments and appropriately understand it, the reader would be well advised to become familiar with the entire trilogy: *Fundamentals of Measurement and Representation in Natural Systems* (FM, 1978); *Anticipatory Systems. Philosophical, Methodological and Mathematical Foundations* (AS, 1985); and *Life Itself. A Comprehensive Inquiry into the Nature, Origin, and Fabrication of Life* (LI, 1991). In their unity, they define Robert Rosen, their author, as an original and provocative scholar. Each of the three books is a self-contained monograph; but only understood in their unity, indeed, as a trilogy, do they provide the reader the opportunity to perceive their interconnectedness. To measure life is different from all other forms of measurement; to understand life is to acknowledge complexity. And once complexity is accounted for, anticipatory processes, corresponding to a comprehension of causality that transcends determinism, can be accounted for as a characteristic of the dynamics of the living.

Preliminaries

Mathematics and biology are subjects that rarely blend. This does not have to be so. Quite a few mathematicians and biologists have brought up their own frustration with each other's methods. Indeed, some biologists – at least those with a “traditional” background – would confirm that their passion for science found its reward in a domain of inquiry that was less mathematical than others. Computation, which after all is automated mathematics, is affecting a change, but not yet in the sense that biologists suddenly become passionate mathematicians. Robert Rosen's entire work – and in particular his contributions to the understanding of what defines the living – utilizes mathematics and biology. This is a difficult position: mathematicians are not necessarily conversant in matters outside their knowledge domain (which they consider universal); biologists prefer descriptions different

from those specific to mathematics. Given the difference between mathematical and biological knowledge, and given the fact that the respective practitioners are not conversant in each other's "language," Rosen, educated and fluent in both mathematics and biology, had a tough time in seeing his work accepted, and an even tougher time in having it properly understood.

These preliminary remarks are undoubtedly connected to the choice I made to write *Prolegomena* – not an Introduction – to the second edition of Rosen's *AS*. It was Immanuel Kant who, after his disappointment with a superficial and less than competent review of his *Kritik der reinen Vernunft* (1781; *Critique of Pure Reason*, as it is called in English), wrote *Prolegomena to Any Future Metaphysics That Will Be Able to Present Itself as a Science* (1783). Among the many questions he raised, "How can the intuition of the object occur before the experience of the object?" is of particular significance to the subject of anticipation. *Prolegomena* are to be understood as preliminaries for defining a subject. As a matter of fact, Kant, who himself indulged in mathematics, paid quite a bit of attention to *prolepsis*, which predates the word *antecipere* and the subject of *anticipation*. It represents the pre-conception, i.e., the preliminary understanding that eventually leads to our knowledge of the world (cf. Epicurus and the so-called *Stoa* – phases in Stoicism – whose ideas were conveyed indirectly through Roman texts). Although the concept of *prolepsis* is associated with anticipation, I will not venture to claim that anticipation as a knowledge domain originates 300 years BCE, or even from Kant. His *Prolegomena* are rather an inspiration for framing Rosen's *AS*. We know how the first edition was reviewed; we also know how it fared and, moreover, why a second edition is necessary. (Incidentally, Kant produced a second edition of his *Critique of Pure Reason* in 1787, i.e., six years after the first. The *Prolegomena* were very useful in clarifying some of the ideas and misconceptions of his book on reason.)

In the spirit in which Kant was mentioned, it is significant that Rosen's "trilogy" Measurement – Anticipation – Life (cf. also Louie 2008, p. 290) be juxtaposed to that of the famous idealist philosopher: *Pure Reason – Practical Reason – Judgment* (Kant 1781, 1788, 1790). The architecture of the arguments, leading to a coherent view, can only be properly recognized if we look at the whole. Admiring the entrance to a cathedral (or any other architectural creation) is never so convincing as the exploration of the entire edifice and the experience of the space and time it encapsulates.

In these preliminaries, I would also like to associate Kant's question regarding the role of intuition, as an anticipation, to some recent scientific reports. "Adaptive prediction of environmental changes by microorganisms" (Mitchell et al. 2009); or "Early-warning signals for critical transitions" (Scheffer et al. 2009) or "Stimulus Predictability Reduces Responses in Primary Visual Cortex" (Alink et al. 2010), to name recent works, are answers, even if only indirect, to his question. They qualify, however, as examples, not as foundational theories, of how far research in anticipation reaches out in addressing various aspects of life and living. The fact that even the most rudimentary forms of life (microorganisms) display anticipatory characteristics clearly aligns with Rosen's description in *AS* of the monocoell and its phototropic behavior. Furthermore, perception processes, in particular those related

to seeing, allow for an optimum in brain functioning (“energy saving” feature). They correspond to our understanding of anticipation as an underlying process from which the evolutionary process benefits.

But before Kant, the future – which is essentially the focus of anticipation (regardless of how we define it) – was of interest to the most intriguing mathematics. Were mathematicians such as Blaise Pascal, Pierre de Fermat, or Jakob Bernoulli addicted to gambling (of one sort or another), or actually intrigued by the possibility of delivering predictive or even anticipatory descriptions? Winning the lottery could be rewarding; but so can the prediction of a successful course of action. Bernoulli’s *Ars conjectandi* (which [Collani 2006](#)) brought to my attention as a precursor of anticipatory modeling), and for that matter game theory, in particular the work of John Forbes Nash, Jr. years later (which afforded him a Nobel Prize) are yet other examples impossible to ignore as we define a context for understanding what anticipation is. The cultural context is very rich and obviously extends to art and literature. The examples mentioned are only indicative of the variety of perspectives from which we can examine the subject of anticipation. With the exception of Bernoulli’s book, whose object is conjecture in its broadest sense, in our days we encounter a rich variety of examples of particular predictive efforts. Humankind is pursuing increasingly risky endeavors: space exploration, genetic engineering, deep ocean oil exploration, financial instruments (e.g., derivatives). Therefore, the need to develop predictive procedures for evaluating the outcome increases.

Particular perspectives and specific areas of investigation (cognitive science, artificial intelligence, ALife, synthetic life, economics, aesthetics, among others) – which will be mentioned in the Prolegomena – are rather illustrative of the ubiquity of anticipatory processes. But they are not a substitute for a scientific foundation, which can only be multidisciplinary. Rosen’s *AS* conjures not only philosophy, mathematics, and methodology (identified as such in his book’s subtitle), but also developments in all those sciences that made possible the current focus on the living. Therefore it qualifies as a theoretic contribution upon which the community of researchers interested in anticipation can further build. For instance, no one can ignore that advances in understanding a variety of forms of creativity (scientific, technological, artistic, etc.) have allowed for a higher acceptance of the notions associated with anticipatory systems. However, such progress has not yet resulted in a better understanding of creativity as an expression of anticipation.

In March 2008, Springer Publishers contacted me regarding its intention to publish a second edition of *AS*. Since that time, the “state of the art” in anticipation research has continued to change on account of a rapidly increasing body of experimental evidence (cf. [Nadin 2010a](#), [Nadin 2011a](#), [2012a](#)), as well as research on the conceptual level. It became obvious to me that to write an Introduction in the classical form would not do justice to the book, to the author, to the subject. And it would not contribute to the type of research that led Rosen to write his book as part of the trilogy mentioned above. *Anticipatory Systems* is being republished in a new context. It can, and should be, read having *FM* and *LI* in mind. Albeit, the second edition is not only the occasion to correct errors (characteristic of publications in the pre-word processing age), but also to understand the impact of the notions it

advanced. The assignment implied a commitment I was not sure that I was willing to make, even after having argued in favor of a second edition of *AS*. My own research (2009a, 2010b, 2010c) takes the best of my time and effort. Many colleagues (whose opinion I asked for) guided my own decision-making and generously provided extremely useful references. In the meanwhile, and on the initiative of George Klir, General Editor of the Series, I prepared a special issue on Anticipation for the *International Journal of General Systems* (Nadin 2010a) – the Journal that previously published Rosen’s articles. This was followed by another thematic issue on anticipation (Nadin 2011b, Nadin 2012b). And when, finally, the Prolegomena became an inescapable project, I was able to build upon the effort made so far in understanding Rosen’s work, the context in which it was published, its impact. Distinguished colleagues who respect Rosen’s work helped. Given my own long-term dedication to the subject, it is clear that these Prolegomena (in the Kantian tradition) are meant to provide a context in which the work of many, together with my own, will be related to that of Robert Rosen.

Allow me a presumption here: The fact that there is so much to consider in defining the context would have pleased him. I wish that Robert Rosen himself could have written the preface to this second edition of his book; but I will not, by any means, second-guess him.

The Path to the Publication of *AS*

The perspective of time and the evidence of increasing interest from the scientific community in understanding anticipatory processes speak in favor of describing the perspective from which anticipation was initially defined. Moreover, the ever-increasing variety of understandings associated with the concept invites clarification. In a nutshell, this is all I want to provide in these Prolegomena. Twenty-seven years ago, Robert Rosen’s book on anticipation first reached its readers. It was actually written in the first six months of 1979, but did not have an easy path on the way to publication. My own book, *Mind – Anticipation and Chaos* (1991) introducing the concept of anticipation was published six years later (it was also written well before publication).

Rosen’s scientific legacy is the result of scientific commitment that excluded compromise as a path to acceptance or recognition. It also excluded self-delusion: In his will, Rosen left his work (and library) to Judith, the daughter who stood by his side until his untimely death, and who does her very best to share what she learned from her father with those who are interested. The testament came with the following proviso: “You don’t have to do anything with it, Jude. In my opinion, either it continues based on its own merits or it dies a natural death. If it can’t stand on its own merits, then it doesn’t deserve to,” (Rosen 2008). For the reader inclined to see in the publication of the Second Edition of *AS*, a contradiction of Robert Rosen’s position, only this need be said: Many young (and not so young) researchers asked for it. Interest in someone’s writing is an acknowledgment of merit. It is worthwhile mentioning that the book continues to be frequently cited

(sometimes through secondary sources). Given the limited access to the original book, misinterpretations, prompted by less than adequate citations (errors in the first edition transmitted from one quoting author to another) sometimes led to confusion. One of those who helped me in preparing this text (Olaf Wolkenhauer, Systems Biology, Rostock University) recently wrote to me: “We are getting tired of guessing what Rosen meant.” At least as far as *AS* is concerned, no guessing should replace consulting the work itself.

How *AS* came to be published deserves a short note because science and integrity, associated with originality, cannot be conceived as independent of each other. Based on some accounts, Rosen’s manuscript was reviewed by an old nemesis of Rashevsky, and publication was quashed. Six years later, it eventually became the first volume in the *International Series on Systems Science and Engineering*, published by Pergamon Press, under the heading of the International Federation for Systems Research. The Federation itself (founded in 1980) was no less controversial. In the spirit of the activity of those who set the foundation for a system’s approach (Wiener 1948, Ashby 1956, Bertalanffy 1968), it challenged excessive specialization, advancing a holistic view of the world. George Klir, its first president, practiced a systems approach focused on knowledge structures. He met Robert Rosen in 1970, after visiting von Bertalanffy at SUNY–Buffalo (where von Bertalanffy, professor in the School of Social Sciences introduced him to Rosen). They remained in touch, and between 1971 and 1972 they explored the feasibility of a new journal. In 1974, the first issue of the *International Journal of General Systems* was published. In acknowledging Rosen (“He was in some sense a co-founder of the Journal”), Klir makes note of the fact that Rosen was an active Member of the Board and published constantly from the first issue on. In 1975, an opening at the Department of Systems Science at SUNY–Binghamton prompted Klir to recommend to his Dean, Walter Lowen, that the University recruits Robert Rosen. (Rosen described a visit by Klir and Lowen to Buffalo in 1974.) When asked, Rosen, a scientist of high integrity, would not consider moving without his closest collaborators (Howard Pattee and Narendra Goel) at the Center for Theoretical Biology at SUNY–Buffalo. In the end, as the Center was abolished in 1975, Rosen accepted the generous offer from Dalhousie University (Killam Professor, “like a five-year sabbatical”) in Nova Scotia, Canada, while Pattee and Goel moved to Binghamton; they all remained in touch. In 1978, Klir published Rosen’s *FM* in the General Systems Research Series (also a first volume in the series) of Elsevier. Trusting Klir, Rosen finally submitted *AS* to him. Klir realized that it was a difficult text, by no means typical of publications on biology, systems theory, mathematics, or philosophy – disciplines that were integrated in this text – of that time, or of any time, for that matter. His interest in Robert Rosen’s work was the result of numerous interactions in which scholarship and character proved flawless. One of the reasons I accepted to write these Prolegomena is because George Klir deserves our respect for his dedication to scientific integrity. He realized the need for this second edition and helped in making it happen.

As far as my inquiry regarding the beginnings of Rosen’s interest in the subject of anticipation shows, the early 1970s were pretty much the time of his attempts to specifically address the subject. But let’s be more precise, not for the sake of

archival passion, rather in order to place the subject in the larger framework of his research. Since 1957, when Rosen joined Rashevsky's Committee on Mathematical Biology at the University of Chicago, he was prepared to make relational biology the reference for his own theoretic work. Rosen's discovery of the "(M,R)-Systems" was the starting point. In order to define the living in its concrete embodiment as organism, he advanced a class of relational models called "(M,R)-Systems". M stands for metabolism; R for repair; and the system defines relational cell models that describe organisms. In this view, the object of inquiry of biology is the class of material realizations of a particular relational structure expressed in the "(M,R)-Systems". From here on, a large body of publications testifies to the intellectual effort of defining what life itself is. A material system is an organism if and only if it is closed to efficient causation (Rosen 1991). It is worth noting that the definition is focused on causality (in the Aristotelian tradition of material, formal, efficient, and final causes); also, that life is embodied in organisms. The matter of organisms is important; but what defines life is *what* organisms actually do – moreover, *why* they do it. In his *LI*, Rosen dealt with the "necessary condition, not sufficient one, for a material system to be an organism." Complexity, which is characteristic of life, and which in the final analysis explains anticipation, "is the habitat of life . . . not life itself." Let us take note that complexity is defined ontologically – as pertaining to existence – not epistemologically – as pertaining to our knowledge of what exists. Rosen ascertained that something else is needed to characterize what is alive from what is complex (Rosen 2000). The simplest "(M,R)-system" is one of replication, repair and metabolism entailing one another. It is, of course, a formal representation of the living (organism, cell).

Between *AS* and his next book, Rosen's original contributions result from a process of discovery impressive in its breadth. His subject was neither more nor less than what life is, after all. The manuscript of *AS* submitted to Klir was conceived over a long time, with many of its hypotheses subjected to discussions in various colloquia, seminars, and conferences. The original manuscript (typed) – preserved by his most talented student (Rosen's own characterization of Aloisius Louie) – went through a judicious editing process. In science, new perspectives rarely break through on account of their soundness. And even less on account of their novelty. Like anyone else in society, scientists are captive to their respective views and quite often unwilling to allow opposing views to enter the arena of public debate. A rather nasty review of one of Rosen's books, *Dynamical System Theory in Biology*, Vol. I, 1970 (Cohen 1971), made Rosen give up publication of the second volume (the manuscript still exists), and even decide to never again write or publish textbooks. The review states, "Physics envy is the curse of biology," (p. 675). Rosen was not in the envy business. Respectful of physics, and working closely with physicists, he rather questioned a physics-based foundation of biology and tried to advance an alternative foundation. Let it be spelled out: In this respect, his approach and my own have much in common.

This brings up the second reason for accepting Springer's invitation: Robert Rosen himself. No, I was not one of his students or colleagues. And I have to confess that when I first heard his name – brought to my attention in the spring

of 1992 by a former graduate student of mine, Jeffrey Nickerson (currently Director of the Center for Decision Technologies, Howe School of Technology Management, Stevens Institute of Technology, Castle Point-on-Hudson, NJ) – I could not relate it to anything of interest to me at that time. My book, *Mind – Anticipation and Chaos*, the result of inquiries into cognitive processes and semiotics, gave me the illusion of being the first to project the notion of anticipation into scientific dialog. In the 1970s, my interest in the scientific foundation of aesthetics (information aesthetics, in particular) prompted the realization that artistic endeavors, and by extension creativity, imply anticipatory processes (cf. Nadin 1972). But, as I would discover, that was also the time when Rosen started his own inquiry into the relevance of predictive models in society. I was wrong in my illusion of being the first, but not unhappy that an intellectual of his worth considered anticipation a subject of scientific interest. The relative simultaneity of our independent interest in the subject is probably not accidental. In the second part of these Prolegomena, I shall return to the “broader picture,” i.e., to all those persons who at that particular time (after a world war with millions of victims) were asking questions pertinent to a future that seemed unstable (the cold war, nuclear weapons, economic and political instability). It is by no means incidental that such matters preoccupied researchers in the “free world” (as the West defined itself) as well as in the self-described “communist paradise” (the Eastern Block and the Soviet Union). That was a time of many events in which the future begged for some acknowledgment. My library research (at Brown University, Ohio State University, and even at OCLC in Columbus, Ohio) on the key words *anticipation*, *anticipatory systems*, *anticipatory processes* did not identify anticipation as a subject. Nickerson’s own inquisitive energy helped me discover Rosen’s book, which I wish I had read before writing mine. The result of this late discovery was my letter of March 24, 1995 to Rosen. He answered, “I wasn’t aware of your book either. It looks beautiful. I think books should be works of art.” He went on to say:

I’ve obliquely been continuing my work on anticipation, which as you know is a very large subject; in fact, a whole new way of looking at the world. It played a major role in developing a concept I called *complexity* [italics his].... I have another book (*Life Itself*, Columbia University Press, 1991) in which this aspect is developed.

We exchanged copies of our books; and I was hoping that we would meet. It was not to be. During my sabbatical at Stanford University (Spring, 1999), Dr. Daniel Dubois, of the now firmly established Center for Hyperincursion and Anticipation in Ordered Systems (CHAOS), at the University of Liège, Belgium, invited me to prepare a presentation for the Conference on Computing Anticipatory Systems (CASYS, 1999). I dedicated my text to Robert Rosen’s memory. (Later, during a lovely private conversation, Dubois mentioned that he was not aware of Rosen’s premature death, although he knew that Rosen had been severely ill.) Yes, I still feel a sense of loss. I owe it to his memory to write these Prolegomena, even though (as stated above) I wish that he himself could have prefaced this second edition.

It is probably less important to the science to which we are dedicated than to maintaining a sense of academic interconnectedness that such considerations

be shared. The reason I brought them up is straightforward: Many in academia respected Robert Rosen, but the extent to which academia accepted his work by no means reflected an understanding of its originality. It is worth mentioning that Mickulecky – who identifies himself as a colleague – called him “the Newton of biology,” (Mickulecky 2007), but it is also inconsequential. So is the title “Biology’s Einstein” (Staiger 1990). Hyperbole does not carry value judgments, rather emotional content. As we shall see, only two authors reviewed *AS*: one was a graduate student, stimulated to do so by George Klir; the other was a Hungarian scientist interested in control theory. A prior book (*Theoretical Biology and Complexity*, 1985b), edited by Rosen, in which Rosen’s own text brought up anticipation, was also barely reviewed, and mostly misunderstood. Even now, when anticipation is no longer a concept prohibited in scientific discourse, hundreds of articles are published with nominal reference to *AS*, and only very rarely with the understanding of Rosen’s comprehensive epistemology. This should not be construed as an expression of anti-Rosen sentiment. Both hyperbole and marginal acknowledgment define yet another reason to give researchers the foundational work that gives meaning to their inquiry and helps in advancing research in the field. The very active discussion on the Rosen mailing list (rosen@home.ease.lsoft.com) on aspects of Rosen’s writings – Rosen would at most have glanced at such mailing lists – will probably benefit from the publication of this book.

In the Perspective of Relational Biology

The purpose of these Prolegomena is by no means to explain *AS*. It speaks for itself, in a crisp but not facile language. After so many years since its publication, it continues to stimulate contributions – theoretic and experimental – of significance. But the context has changed. The life sciences pretty much take the lead today; no need to envy physics. (In a recent book, Louie smuggled in a polemic note: “Biology-envy is the curse of computing science;” cf. 2009, p. 261.) The pendulum has swung from the obsession with physics and chemistry – no less respectable and reputable in our time – to infatuation with genes, cells (stem cells more than any other), protein folding, and synthetic life. What has not changed is the need to understand the fundamental characteristics of the living. And this is what distinguishes Rosen from most researchers in this domain. These Prolegomena to the second edition of *AS* actually report on the state of the art in anticipation research. In other words, they present the indisputable impact that *AS* has had, regardless of whether those who speak “prose” (to bring up Molière’s character, Monsieur Jourdain) know that they do it – i.e., are aware of Rosen’s work – or do not – i.e., have never heard of him, or discard his work as speculative. For someone outside academic dialog, this could appear as an attempt to see how ideas percolate. The psychology of the process (the obsession with “who was first,” “who owns what,” or “whose understanding,” etc.) is a subject for others, especially because this never affords better understanding of the subject.

While he was working on *AS*, which was *in status nascendi* for almost 15 years, Rosen pursued a very ambitious research agenda. His doctoral thesis, which advanced the “(M,R)-Systems” opened a new perspective within which anticipation is only one aspect. This needs to be brought up since in his autobiographical notes, Rosen made a specific reference: “... the “(M,R)-Systems” have an inherent anticipatory aspect, built into their organization.” Still, as we read his *Autobiographical Reminiscences* (2006a), it becomes clear that in implicit terms, the entire focus on relational biology, in line with Rashevsky’s view, is conducive to a line of inquiry that ultimately questions the centuries-old reductionist-deterministic foundations of biology. This is the crux of the matter. Expressed otherwise, the seed of inquiry leading to anticipation is housed in the new perspective from which the “(M,R)-Systems” are derived as a dynamic description of the living cell, obviously contrasted to the atomic model inspired by physics, which is reactive in nature. The biologist, the mathematician, and the philosopher fuse into a new type of scientist. He is no longer willing to further build on the Cartesian foundation, but rather taking up the challenge of submitting an alternative fundamental understanding. Rosen himself brought up the work of Schrödinger (1944), Wiener (1948), and Shannon (1948), as well as game theory, and especially Systems Theory, in particular Bertalanffy and Ashby. Let me quote: “To me, though, and in the light of my own imperative, all those things were potential colors for my palette, but not the palette itself” (Rosen 2006b).

On previous occasions, I pointed out that a name is missing here, and not through some malicious intention: Walter M. Elsasser. Rosen was aware (and respectful) of Elsasser’s work and occasionally referenced his work. The reason we must evoke Elsasser is to provide a broader view of the work in which Rosen was engaged. Educated as a physicist, Elsasser made it the major focus of his work (after he arrived in the USA) to challenge the reductionist understanding of the living. His book, *The Physical Foundation of Biology* (1958, also by Pergamon Press) followed by *Atom and Organism* (1966) and *The Chief Abstraction of Biology* (1975) was a daring attempt to look at what makes life what we know it to be. I would like to point out that *Reflections on a Theory of Organisms* (1987) was, by no coincidence, almost simultaneous with Rosen’s *AS*. (His Measurement book and Elsasser’s book on abstractions of biology appeared in 1978 and 1975, respectively, from the same publisher.) I already confessed that I was unaware of Rosen when my book, *Mind – Anticipation and Chaos*, appeared. I was unaware of Elsasser, as well. During my sabbatical at the University of California–Berkeley (Electrical Engineering and Computer Science), his work was brought to my attention by Dr. Harry Rubin, a distinguished molecular biologist, who wrote the Introduction to the 1998 edition. Elsasser opposed a holistic view to the reductionist model. He proceeds from within the physics to which he remained loyal (given his formative years, cf. *Memoirs of a Physicist in the Atomic Age*, 1977). Under the guidance of, or in interaction with, Werner Heisenberg, Wolfgang Pauli, Albert Einstein, John von Neumann, Hans Bethe, Max Born, Arnold Sommerfeld, and, not to be omitted, Erwin Schrödinger – whose questions “What Is Life?” he adopted, Elsasser tried to provide a foundation for biology as strict as that of physics. Their interaction stimulated the reformulation of fundamental biological questions.

At this juncture, I felt the need to establish the context within which Rosen's contributions were made, in particular those leading to defining anticipatory processes. To this context belongs the activity of the Center for the Study of Democratic Institutions – the brainchild of Robert M. Hutchins, who for many years served as President of the University of Chicago. As seductive as it is, the history of the Center would take us off course from our present aim. It suffices to mention two things. First: Rosen explicitly acknowledged the impact of the Center as his book came together: "The original germinal ideas of which this volume is an outgrowth were developed in 1972, when the author was in residence at the Center for the Study of Democratic Institutions" (1985a). Second: as a member of the Center, Rosen contributed discussion papers over many years. These texts are highly significant to our better understanding of the implications of his research on anticipation. While the fundamental questions led to a new perspective, none of the hypotheses advanced remain exercises in formal biology. Rosen was a very engaged individual; in his own way, he was an activist. He lived his time; he wanted to understand change; he obliged explanations, and even methods of improvement. It was unfair of many of the commentators of his work to see in him a rather esoteric researcher, disconnected from reality, only because his arguments were often accompanied by or articulated in the extremely abstract language of mathematics, in particular, category theory (which he adopted for his uses in biology almost as soon as it appeared). He was a beneficiary of the two "fathers" of category theory: Eilenberg at Columbia University, and MacLane at the University of Chicago (1945, 1950). Subjects such as planning, management, political change, and stable and reliable institutions informed presentations he made at the Center during the 1971–72 academic year, when he was a Visiting Fellow. In an article published seven years later (1979), Rosen made this explicit:

I have come to believe that an understanding of anticipatory systems is crucial not only for biology, but also for any sphere in which decision making based on planning is involved. These are systems which contain predictive models of themselves and their environment, and employ these models to control their present activities (p. 11).

Hutchins conceived the Center as an intellectual community united in the Dialog:

Its members talk about what ought to be done. They come to the conference table as citizens, and their talk is about the common good [...] The Center tries to think about the things it believes its fellow citizens ought to be thinking about (as cited by Rosen 1985a, p. 3).

Among those working at the Center were political scientists, journalists, economists, historians, even philosophers, but not natural scientists. Still, Hutchins' vision and position of principle gave Rosen's presence meaning, as he himself noted, quoting from this visionary intellectual: "Science is not the collection of facts or the accumulation of data. A discipline does not become scientific merely because its professors have acquired a great deal of information." And yet another:

The gadgeteers and data collectors, masquerading as scientists, have threatened to become the supreme chieftains of the scholarly world. As the Renaissance could accuse the Middle Ages of being rich in principles and poor in facts, we are now entitled to inquire whether we are not rich in acts and poor in principles (p. 12).

This was not different from Elsasser's arguments, and was so close to Rosen's own thinking that Rosen realized that working on a theory of biological systems allowed him to formulate the characteristics of biology as an "autonomous science," for which he would then suggest means to formalize. He made a major observation:

The physical structures of organisms play only a minor and secondary role [...] The only requirement which physical structure must fulfill is that it allow the characteristic behaviors themselves to be manifested. Indeed, if this were not so, it would be impossible to understand how a class of systems as utterly diverse in physical structure as that which comprises biological organisms could be recognized as a unity at all.

The Social and the Biological

Rashevsky's relational biology, which Rosen helped develop, stands in contrast to the then dominant analytical approach. Rosen's approach was to focus on functional aspects, on understanding behaviors. John Wilkinson, a Senior Fellow at the Center, extended the invitation to Rosen hoping that his own focus on structure would benefit from interaction with a person focused on function. The parallels between biological processes and social structures led to one of those questions that only Rosen would formulate: "What would it mean if common models of organization could be demonstrated between social and biological structures?" (p. 13). It was very enticing for him to see a variety of disciplines finally cooperating, as it was a challenge to characterize the dynamics of life without having to account for underlying causal structures. In societal situations, the aggregate behavior, involving a multitude of processes, appear quite differently to an observer than to those involved. No less enticing were the considerations regarding the use of social experience as a means for deriving biological insights, and reciprocally, the possibility to develop insights into properties of social systems by building upon biological experiences. Rosen confessed:

In short, the Center seemed to provide me with both the opportunity and the means to explore this virgin territory between biology and society, and to determine whether it was barren or fertile. I thus almost in spite of myself found that I was fulfilling an exhortation of Rashevsky, who had told me years earlier that I could not be a true mathematical biologist until I had concerned myself (as he had) with problems of social organization (p. 14).

From this attempt to establish homologies between social and biological organization, Rosen expanded to predictive models, and realized that the stimulus-reaction explanatory concept could not account for situations in which subjects predict consequences of their own actions, moreover, for situations in which a course of action is changed not as a result of stimuli, but in accordance with a subject's predictive model. The switch from descriptions limited to reactive behavior to the much richer descriptions of what he termed anticipatory behavior resulted from a different understanding of the living. That the agency through which predictions are made turns out to be a model corresponds to the fundamental contributions Rosen

made in defining the “(M,R)-Systems”. It was noted by Kercel (2002, 2007), among others, that Rosen’s epistemology defines properties of logical and mathematical structures. *Impredicativity* is such a property – every functional aspect of the model is contained within another functional component. As we shall see shortly, this is the case of the system and its model unfolding in faster than real time, i.e., definitory of the model, not of reality as such. This means that once we acknowledge the complexity of natural systems, we need the appropriate concepts to describe them, under the assumption that a natural system whose entailment structure is congruent with an impredicative model. But as pervasive as anticipatory behavior was, it was not yet operational in the sense of being easy to translate into a coherent theory, and even less in applications to problems of forecasting and policymaking that were the focus of the Center. The “fortuitous chain of circumstances” described in Rosen’s paper explain why his involvement with the Center can be characterized as yet another element of the context that inspired him, as well as others (members of the Center or not), in questioning the entire analytical foundation of reductionism and determinism.

Readers of *AS* already know that major consideration is given to causality, in particular to phenomena that involve purpose or, alternatively, a goal. It is not the intention of these Prolegomena to offer a *compte rendu* of the book, or of Rosen’s view of anticipation. As already stated, the hope is to provide here a frame of reference. Therefore, from among all those whom Rosen named in his autobiographical notes (and in many other writings), we need to highlight Aristotle, whose work on a typology of causes remains a constant reference. *Causa finalis*, eliminated from scientific vocabulary with the same epistemological fury as vitalism was, found a new champion in Rosen. His strict understanding of dynamics implies finality.

One final note about the onset of Rosen’s work on anticipatory behavior: “Planning, Management, Policies and Strategies: Four Fuzzy Concepts” (1972) was the first of a number of working papers that define his research agenda at the Center. The first lines of this paper could have been written in our days:

It is fair to say that the mood of those concerned with the problems of contemporary society is apocalyptic. It is widely felt that our social structure is in the midst of crises, certainly serious, and perhaps ultimate. [...] The alternative to anarchy is management; and management implies in turn the systematic implementation of specific plans, programs, policies and strategies (p. 1).

Rosen brought up the conceptual requirements for a methodology (“a ‘plan for planning’”) that would allow avoidance of “an infinite and futile anarchic regress.” Given the audience at the Center, i.e., none with a background in mathematics, biology, systems theory, or the like, Rosen built his arguments in favor of defining anticipatory behavior in an almost pedantic manner. But in essence, it was within this context that the major ideas of his future book on anticipatory systems were articulated. The intellectual profile of his listenership and the broad goals of the Center, which Rosen explicitly adhered to, had an impact on formulations, examples, and the general tone. Aware of the fact that “how planning could go wrong” was on the minds of his Fellows at the Center, he explicitly addressed

the question, taking note of the fact that a system's integrated perspective is not bulletproof, just as "the defect of any part of a sensory mechanism in an organism leads to a particular array of symptoms," (1972, p. 3 and 1974, p. 250). At the center of his conception is the "Principle of Function Change": the same structure is capable of simultaneously manifesting a variety of functions. Rosen remained fully dedicated to his research in the foundations of biology and, in a broader sense, to the broader task of reconsidering the reactive paradigm. He was aware of the need to focus on what a model is, and to further define the relation between a biological entity and its model; that is, the relation between something represented and its representation. It is within this broader realm that Rosen realized the urgency of understanding how an open system (the natural system) and its model – always less open – understood in their relative unity, eventually make predictions possible.

Natural and Formal Complexity

Anticipatory Systems followed another foundational text: "Organisms as Causal Systems which are Not Mechanisms: An Essay into the Nature of Complexity" (1985b). By no means to be ignored, the other two contributions – "The Dynamics of Energetics of Complex Real Systems" (by I.W. Richardson) and "Categorical System Theory" (by A.H. Louie) – make it clear that Rosen's research reached another level; those who worked with him were encouraged to examine the various implications of higher complexity definitory of the living. The distinction between simple systems (or mechanisms) and organisms came clearly into focus. Rosen denied, in very clear formulations, that biology is nothing more than a particular case for physics (p. 166), and argued in favor of a mathematical language appropriate to the task, which is, in his view, category theory. Concluding remark: "Complex systems, unlike simple ones, admit a category of final causation, or anticipation, in a perfectly rigorous and nonmystical way," (p. 166). It is in this very well organized essay, of a clarity not frequently matched in his very rich list of articles and books, that Rosen defined a fundamentally new perspective. Schrödinger's question "What is Life?" – which became the focus of his work – led to his description of "relational biology," a concept originating, as already mentioned, with [Rashevsky \(1954\)](#), and which led to the realization that only after abstracting "away the physics and the chemistry," ([Rosen 1985b](#), p. 172) can we reach the organizational features common to all living systems. Rashevsky used graphs, whose "nodes were biological functions" and whose directed edges were "relations of temporal or logical procedure," (p. 172). But, as Rosen noticed, his mentor was ahead of his time:

... the time was quite wrong for his new relational ideas to find any acceptance anywhere. In biology, the 'golden age' of molecular biology was just beginning; experimentalists had no time or use for anything of this kind. Those who considered themselves theorists either were preoccupied with the reductionist modeling that Rashevsky had earlier taught them or were bemused by seductive ideas of 'information theory,' games theory, cybernetics, and the like, regarded Rashevsky and his ideas as generally archaic because he did not take direct cognizance of their enthusiasms (p. 173).

A great deal of effort was spent on defining the “(M,R)-Systems”, in particular on replication mechanisms inherent in the organizational features represented. However, the centerpiece, and appropriately so, is the modeling relation between a natural system and a formal one. Any reader of *AS* would be well advised to read Rosen’s essay (even though its main line of argument reverberates in the book). It is here that the intrinsic limitations of the Newtonian paradigm are spelled out in detail. And it is here, as well, that the major subject of causality, including the teleological, is addressed up front (cf. p. 192). Moreover, it is here that the “mathematical image of a complex system” comes into focus, and becomes subject to mathematical category theory (although the author did not specifically apply it here).

From the very rich text, I would like to refer to Rosen’s considerations on information, specifically, on an alternate approach that relates to his preoccupation with measurement. He defined information as “anything that is or can be the answer to a question” (cf. p. 197). This prompts the observation that formal logic (“including mathematics,” as he put it) does not account for the interrogative. Therefore, information cannot be formally characterized. Rosen used the formalism of implications (If A, then B) in order to eventually formulate a variational form (If δA , then δB) that brought up measurement: “If (initial conditions), then (meter reading)?” and an associated formulation on variations: If (I make certain assumptions), then (what follows?). This is, in his words, “analogous to prediction” (p. 199). The conclusion is powerful: “When formal systems (i.e., logic and mathematics) are used to construct images of what is going on in the world, then interrogations and implications become associated with ideas of causality (p. 199). The reader is encouraged to realize that this is exactly why the Newtonian paradigm cannot accept Aristotle’s *causa finalis*: a (formally) logical system that does not have what it takes to represent interrogation, cannot account for information that always involves a telic aspect: the “What for?” of information. The conclusion is simple (and elegantly formulated):

Like early man, who could see the earth every evening just by watching the sky but could not understand what he was seeing, we have been unable to understand what every organism is telling us. It cannot be stressed strongly enough that the transition from simplicity to complexity is not merely a technical matter to be handled within the Newtonian paradigm; complexity is not just complication but a whole new theoretical world, with a whole new physics associated with it (p. 202).

There is an old question that informs these Prolegomena: If a tree falls in the woods and no one is around to hear it, does it make a sound? In semiotics, one of the research fields from within which my own notion of anticipation took shape, nothing is a sign unless interpreted as a sign. The noise caused by the falling tree is a physical phenomenon corresponding to friction. It propagates at a distance that corresponds to the energy involved (the falling of a huge tree can be heard at a farther distance than the falling of a bush). The energy dissipated in the process can be measured exactly. In trying to define natural law, Laplace (1820, as quoted in [Rosen 1985a](#), p. 9) convincingly described the kind of inferences possible in the reductionist world: An intelligence knowing, at a given instant in time, all forces

acting in nature, as well as the momentary position of all things of which the universe consists, would be able to comprehend the motions of the largest bodies of the world, as well as the lightest atoms in one single formula. To him, nothing would be uncertain, both past and future would be present in this eyes. In the years in which Rosen challenged a description of the world that simply does not account for the richness of life, I myself referred not only to Laplace, but to *Ecclesiastes*: “There is no new thing under the sun” (Nadin 1987). Everything is given, and with it, the laws describing it. We need only a good machine to reconstitute the past from the energy that preserved the noise of the falling tree, as it preserves all the thoughts ever expressed by those speaking to each other. The oscillations of air molecules could help us hear what Aristotle said, and even Socrates, whose words, we assume, Plato wrote down (or made up). My text on the mind, coming together within the timeframe when anticipation was becoming a necessary construct for understanding how minds interact, challenges the acceptance of reductionism while actually having as its object a novel, Umberto Eco’s *The Name of the Rose*. The detective story was probably written from end to beginning, or so it seems. It has a clear final cause, and it offered the author, a distinguished historian of the Middle Ages, the occasion to pose questions relevant to how representations are elaborated. Is there something there – a person, a landscape, or a process – that we simply describe, draw, take a picture of? Or do we actually notice that what is alive induces changes in the observing subject that eventually result in a representation? Even in the universe of physics, the static notion of representation was debunked as quantum mechanics postulated that to measure is to disturb. Rosen (1978, and myself, Nadin 1959) in other ways, said: “to measure is to BE disturbed.” That is, the dynamics of the measured affects the dynamics of the measuring device. Every interpretation is the result of interactions.

Together with the rather impressive number of Center presentations (published in the *International Journal of General Systems*; see references for details) that preceded the book, *AS* invites consideration of its echo in the scientific community. Please remember the question, “If a tree falls in the woods and no one hears the noise, does the event register as directly consequential?” It also invites consideration of Rosen’s essay, “Organisms as causal systems which are not mechanisms” (1985b) in the *Theoretical Biology and Complexity* volume. Let’s be up front: *AS* prompted two reviews: one by Minch (1986), at that time a graduate student at Binghamton, and one by Vámos (1987) of the Technical University of Budapest (Hungary). The Essay volume attracted René Thom, the distinguished mathematician (Catastrophe Theory is associated with his name), Lee Segel (Weizmann Institute of Science, Israel), Lev Ginzburg (SUNY–Stony Brook), and P.T. Saunders (King’s College) to review it. In the perspective of time, this is rather little given the significance of the work. But it is also telling in respect to the difficult cognitive challenge that the work posed, and still poses. Minch, now a respected researcher in his own right, might not have fully realized the impact of the radical ideas that Rosen advanced, but everything in the review is evidence of solid judgment and the desire to understand. He stated: “The essential difference between reactive and anticipatory systems is that reactive control depends on correction of an existing deviation, while

anticipatory control depends on preventions of a predicted deviation” (cf. p. 405). For anyone trying today to convey to the scientific establishment why the study of anticipation is relevant, this sentence from Minch’s review says it all. Minch thoroughly referred to the *modeling relation* – “between a natural system and a formal system” – and to their linkage. He was able to realize the importance of a new understanding of time (“In particular, he shows how we can view models and systems as parameterized by different times” p. 406). The review deserves to be quoted in more detail than appropriate in Prolegomena. The book as a whole, Minch states, is both radical and profound.

It is radical because it not only develops and propounds a paradigm, which is very different from the traditional, but also finds inadequacies in the epistemological roots of science, and overcomes these inadequacies. It is profound because of the depth of the discussion and the extent of its implications (p. 408).

Vámos could not find anything new. In the Essay reviews, Thom admired “an extremely interesting piece of epistemological thinking,” as well as the discussion on causality, “The rediscovery of Aristotelian causality theory, after centuries of blind positivist rejection, has to be hailed as one of the major events in modern philosophy of science.” Neither Segel (“I oppose his urgings to go beyond the evolving state description that was so successful in particle physics,” 1987), nor Ginzburg (1986) realized the significance of Rosen’s model. Saunders, “fascinated by the third chapter (i.e., Rosen’s text) is also taken by the novelty of the approach to causality and the non-Newtonian dynamic system.

Various Understandings of Anticipation

At this moment, the reader of the Prolegomena dedicated to what supports the science that Rosen attempted to initiate might call into question the wisdom of printing a second edition of a book less than enthusiastically received since its beginning – but out of print, nevertheless. I hasten to add that my own survey of anticipation-pertinent scientific publications has resulted in a very interesting observation: Very few mainstream researchers quote Rosen directly; secondary sources, in articles inspired by Rosen’s work, are usually quoted. Rosen is present, i.e., his ideas are either continuously reinvented – I can imagine him smiling about this – or, better yet, there is a definite Rosen presence even in research that is ultimately divergent from his understanding of anticipation. Here I refer explicitly to various attempts to get machines to anticipate one way or another – a subject to which I must return since there is so much and often very good work to survey. The destiny of Rosen’s writings, not unlike his actual destiny, might be a good subject for a novel or a movie. After all, John Simon’s apt description (*New York Magazine*, 1990), inspired by Richard Nelson’s play *Some Americans Abroad*, was an eye-opener to many who still maintain an idealized view of academia, or are convinced that science is a *sui generis* immaculate conception enterprise in which the best always wins.

The intensity of hatred, infighting, and back-stabbing increases with the marginality of a profession; hence, for rivalry, animus, and vindictiveness, there is no business like education. Anyone who has put in time in academia has witnessed intrigue to make a Renaissance Italian dukedom or a Reformation German principality look like an idyll by Theocritus.

Rosen faced bureaucratic imbecility a bit more than his peers did, and became the victim of that infighting and back-stabbing. He distanced himself as much as possible from this behavior. But after all is said and done, and while the difficulties he faced affected him, this is not what defines Rosen as a scholar. It would be unfair to his legacy to put more weight on the unfairness he faced than on the original thinking that defines his contribution. No scientist of integrity will lightly challenge the fundamental epistemological assumptions informing the dominant understanding of life within and outside the scientific community. Generation after generation, we were all educated, and continue to be educated, in the Cartesian understanding. A highly successful body of knowledge testifies to the revolutionary power of this explanatory model of the world. Still, before Rosen, and after Rosen, positions were articulated in which Cartesian doubt – *Dubito ergo sum* – is expressed, moreover in which alternative explanations are advanced (cf. [Wigner 1961, 1982](#)). On several occasions, I presented such views ([Nadin 2000, 2003, 2009b](#), for example), informed by Rosen’s work and by other attempts to free science from a limiting view of how knowledge is acquired.

Rosen’s realization of the limits of the reaction paradigm is part of his broad conception of the living. Our ability to gain knowledge about it is affected by the Cartesian perspective. To transcend this view, scientists ought to “discard knowledge” (as Niels Bohr put it), and to see the world anew. In a letter (1993, cf. *Praefatio*, [Louie 2009](#)), Rosen alludes to how the “official” position of science often leads to opportunistic positions: “The actual situation reminds me of when I used to travel in Eastern Europe in the old days, when everyone was officially a Dialectical Materialist, but unofficially, behind closed doors, nobody was a Dialectical Materialist.” Due to my own life story, I happen to know what this means. My own understanding of anticipation was informed by semiotics – which Rosen and some of his colleagues considered worthy of their attention (they referred mainly to the symbol). At the time (1980–1985), I was teaching at the Rhode Island School of Design and advised some very creative students. I also served as adjunct professor at Brown University, working with the Semiotics Group and students in Computer Science. Cognitive science, in particular Libet’s work on readiness potential ([Libet et al. 1983](#)), also informed my research. As Eminent Scholar in Art and Design Technology (Ohio State University, 1985–1989), I was confronted by what Rosen would have qualified as the “mechanistic view of creativity,” characteristic of the early days of fascination with computers and their applications in modeling, simulation, and animation. This was the place where “flying logos” originated, where computer graphics – machine-generated imagery and computer-supported animation – made national headlines. The effort received the usual funding (National Science Foundation, Department of Defense, and the like), prompted less by scientific significance and more by media attention. Ever

since my formative years in Romania, first at the Polytechnic Institute and then as a graduate and doctoral student at the University of Bucharest, the question that shaped my intellectual profile concerned creativity, in particular: Can machines be creative? Better yet: Is creativity an expression of deterministic processes?

Today I know that this is a typical Elsasser problem, as it is also a Rosen problem. And it lies at the confluence of the physical (i.e., matter), as a substratum of all there is, and the dynamics of the living. As I wrote my first computer graphics programs (late 1960s), I realized that they encapsulated knowledge of visual expression and representation, and allowed for high performance of repetitive tasks. But the essence of any creative act is that it results in something that has never existed, not in the mindless reproduction of what is already available.

At Ohio State, I could have easily fallen prey to the comfort of a prestigious tenured position. Playing the usual funding games – if you correctly assess the direction from which the “funding winds” blow and don’t challenge established science, you get to “kiss the girl” – and making the conference rounds was part of it. But I did not want that. My concern with the multitude aspects of creativity brought me close to the then still incipient interest in the role of the brain, and into the mind-brain discussion. Intellectually, this was the hottest subject, probably because it took place at the confluence of disciplines (and had a clear European flair, as with Eccles).

I left Ohio State – probably as Rosen left Chicago or Buffalo – but not before accepting the invitation of the Graduate School to give a lecture. My take on anticipation, which was the focus of this lecture, was based on Libet’s measurements. I was not interested in free will, as I did not focus on how synapses actually take place. The scientific question I tried to answer was, “How do minds anticipate?” that is, how brain activity is triggered before an action, not in reaction to something else. “How does the brain know in advance that I will move my arm or scratch my head, or avoid a collision?” In addressing the question, I used the mathematical model of dynamic systems, and I advanced some hypotheses: The mind controls the brain; actually interactions of minds make anticipation possible. Anticipation can be described as an attractor within a space of many possible configurations. The lecture devoted some consideration to senescence (in particular, dementia), and even more to creativity. This lecture, which somehow paralleled Rosen’s lectures at the Center in Santa Barbara, eventually became a manuscript in search of a publisher. (I wish I had known George Klir at that time.) The text also defined my priorities as a researcher. Indeed, I did not want to write programs to be used for more flying logos and commercial art garbage. Repetitive tasks were not for me, just as the automation of bad taste, along with the production of mediocrity for satisfying such bad taste, never captured my interest. To give up an endowed chair sounds almost heroic when one thinks about the uncertainties in academia. But it saved my life as a scientist.

At this time, I was back in New York City and had the opportunity to see a fascinating show at the New York Academy of Sciences. Tod Siler, whose artwork was being exhibited, was a Ph.D. candidate at the Massachusetts Institute of Technology, combining art and brain science. His show seemed to reverberate my own thoughts. It seemed to me that if I could find a publisher for my book, his

images would be congenial to my ideas. Fortuitous events brought me to Belser Presse (Stuttgart/Zurich), which produced a series dedicated to scientific texts of broader relevance than the usual monographs. The series “Milestones in Thought and Discovery” published Leibniz’s *Two Letters on the Binary Number System and Chinese Philosophy* (1968); Heisenberg’s *The Laws of Nature and the Structure of Matter* (1967); and the testimony of Furrer (1988), the first German astronaut. These titles were selected by an extremely competent scientific advisory board. The members took a long time deliberating whether my book and Siler’s images should be published, but in the end an exquisite limited edition was printed. It became the preferred gift among an elite, but not necessarily the subject of scientific debate, as was my hope.

And as my new academic endeavors would have it – teaching in Germany for ten years – my focus on anticipation – in the meanwhile informed by Rosen’s work and influenced by my contact with him – led to more theoretic work. It also led to attempts to test hypotheses in various fields of anticipation expression: communication, design, architecture, human-computer interaction, the various arts. In 2002, the antÉ – Institute for Research in Anticipatory Systems was incorporated, and one of its first projects was a hybrid publication: book (*Anticipation – The end is where we start from*, Nadin 2003), Website (a knowledge base for the community of researchers interested in this area), and a DVD (presenting examples of anticipation ranging from chess to a simple protein folding game). This was the first time that some of Rosen’s work was made available in digital format.

With my appointment as Ashbel Smith Professor at the University of Texas at Dallas, the Institute found a new host, and new fields of inquiry. I would not have accepted the endowed chair in Dallas if the terms of my employment had not specifically spelled out a framework of activity corresponding to my total dedication to research in anticipation. Interestingly enough, Rosen himself worked for a year in Dallas (actually in Arlington, part of the greater Dallas–Fort Worth Metroplex) – he did not like it – before his stint in Kyoto. More to the point, his writing on senescence, and my work in addressing the loss of anticipation in the aging somehow fused in the Project *Seneludens* (Nadin 2004). Through brain plasticity (stimulated by involvement in games with a cognitive and physical component), anticipatory characteristics, vital to maintaining balance and a variety of actions, can be maintained.

The Institute also organized three international symposia: Vico’s *Scienza Nuova*, 2005, *Anticipation and Risk Assessment*, 2006 (see Nadin 2009a), and *Time and the Experience of the Virtual*, 2008. A special issue of the new *Journal of Risk and Decision Analysis* is dedicated to Risk and Anticipation. The University gave serious consideration to acquiring Rosen’s library; my own desire to organize an annual Robert Rosen Memorial Lecture will one day be realized.

These details should be read as testimony to a very dedicated interest in a subject that will always have a reference in Rosen’s *AS*. Maybe the best way to conclude these remarks is to set side-by-side one of Rosen’s definitions and one of mine:

Rosen	Nadin
An anticipatory system is a system whose current state is determined by a (predicted) future state.	An anticipatory system is a system whose current state is determined not only by a past state, but also by possible future states.

As subtle as the difference is, it only goes to show that could Rosen be around, he would continue to work on foundations as well as on applications.

Distinguishing between prediction and anticipation is the subject that could be of further help in defining anticipatory processes. Prediction and anticipation are not interchangeable. Predictions are expressions of probabilities, i.e., description based on statistical data and on generalizations (that we call scientific laws). While not unrelated to probabilities, anticipations involve possibilities. Zadeh's genius in defining possibility is expressed in the accepted dicta: Nothing is probable unless it is possible. Not everything possible is probable. The model of itself, which unfolds in faster than real time, in Rosen's definition (1985a) is driven by both probability realizations and possibility projections. It is in respect to this fundamental distinction that I submitted the thesis according to which the complementary nature of the living – physical substratum and specific irreducible dynamics – is expressed in the complementary nature of anticipatory processes (Nadin 2003, 2009c).

A Broader Context – Awareness of Anticipation

The perspective of time and the evidence of increasing interest from the scientific community in understanding anticipatory processes speak in favor of describing the premises for the initial definition of anticipation. The work (1929) of Alfred North Whitehead (1861–1947) advanced the idea that every process involves the past and the anticipation of future possibilities. This thought is part of a larger philosophic tradition sketched out in the attempt to indentify early considerations on the subject. Indeed, let us be aware of the variety of understandings associated with the concept, because otherwise there is a real risk of trivializing anticipation before we know what it is. Burgers (1975) was inspired by Whitehead. Although he came from physics, Burgers brought up choice and the preservation of freedom as coextensive with anticipation. Bennett, an anthropologist, saw anticipation as “the basis for adaptation” (1976a, p. 847). In his book (1976b), the same broad considerations made the object of an entire chapter (VII), in which Whitehead's notion of anticipation, extended to the entire realm of reality, is limited to living systems. Both Burgers and Bennett are part of the larger context in which anticipation slowly became part of the vocabulary of science and philosophy at the end of the last century.

Another area of investigation that leads to explicit considerations of anticipation is psychology. Not unexpectedly, “work and engineering psychology” (Hacker

1978) comes to the realization that goal-oriented activities are expressions of anticipation. The fact that Marx, writing about work as goal oriented (in *Das Kapital*, 1867) becomes a reference in this respect has to do with more than the “style” of scientific writing in Eastern Europe. You needed to provide a good quote from the “classics” (Marx, Engels, Lenin, etc.), and Hacker provided several (“The ideal anticipation of the product as goal” is yet another example; 1978) before you could present your own ideas. Hacker distinguishes between the physical effort of labor and the spiritual effort. The future, embodied in the result of the work defines the various stages of the productive effort (“inverse causality,” 1978, p. 108). Around the time when Rosen advanced his research, Winfried Hacker (currently emeritus of the Technical University in Dresden, Germany) was examining anticipatory expression in work, learning, and playing. Action regulation theory guides his approach. Hacker also analyzed the role of memory and defined perspective memory as relevant to anticipation (1978, p. 292 and following on the sensomotoric). He made very convincing references to [Vygotsky](#) (1934/1964), [Leontiev](#) (1964), and [Galperin](#) (1967), who considered the role of language as an anticipatory expression in various human activities. In a comprehensive study of the many aspects under which anticipation is acknowledged, [Vygotsky and Luria](#) (1970) will indeed have to be mentioned. In his Ph.D. thesis, [Volpert](#) (1969) convincingly brought up the sensory-motoric aspects of anticipation-guided learning. The most relevant contributions, still waiting to be placed in the proper context, are those of Bernstein on the “physiology of activeness” (his terminology). He focused on motor tasks and advanced (beginning 1924) the idea that “Anticipation, or presentiment” (as he calls it) is based on a probabilistic model of the future (cf. [Bernstein 1924, 1935, 1936, 1947, 2004](#)). It is very possible that once research in anticipatory processes expands to include the history of ideas leading to new hypotheses, such and similar contributions will prove significant for the future development of the field. Let me explain this statement through an example.

Feynman, famous for his contributions to quantum electrodynamics (which earned him a Nobel prize, in 1965, shared with Julian Schwinger and Sin-Itiro Tomonaga) is, probably more by intuition than anything else, part of the scientific story of anticipation. The depth of Feynman’s involvement with the subject of computation is significant because he, as opposed to everyone else, brought up anticipation, however indirectly, not from biology, but from computation – that is, exactly where Rosen would have claimed that it cannot be found.

In an article entitled “Simulating Physics with Computers,” Feynman (1982) made relatively clear that he was aware of the distinction between what is represented (Nature – his spelling with a capital N, and nothing else, since physics always laid claim upon it), and the representation (computation). The physical system can be simulated by a machine, but that does not make the machine the same as what it simulates. Not unlike other scientists, Feynman focused on states: the space-time view, “imagining that the points of space and time are all laid out, so to speak, ahead of time.” The computer operation would be to see how changes in the space-time view take place. This is what dynamics is. His drawing is very intuitive (Fig. 1).

Fig. 1 Feynman's (1999) original state diagram

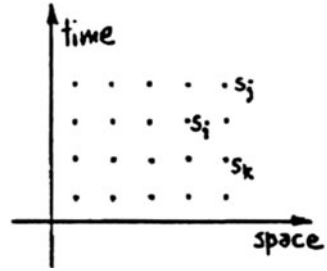

The state s_i at space-time coordinate i is described through a function F (Feynman did not discuss the nature of the function): $s_i = F_i(s_j, s_k, \dots)$. The deterministic view – i.e., the past affects the present – would result, as he noticed, in the cellular automaton: “the value of the function at i only involves the points behind in time, earlier than this time i .” However – and this is the crux of the matter – “just let’s think about a more general kind of computer... whether we could have a wider case of generality, of interconnections.... If F depends on all the points both in the future and the past, what then?” obviously, this is no longer the computation Rosen referred to.

Had Feynman posed his rhetoric question within the context of research in anticipation, the answer would be: If indeed F depends on all the points both in the future and the past, then \rightarrow Anticipation. Defining an anticipatory system as one whose current state depends not only on a previous state and the current state, but also on possible future states, we are in the domain of anticipation. Feynman would answer: “That could be the way physics works” (his words in the article cited).

There is no reason to fantasize over a possible dialog – what he would say, his way of speculating (for which he was famous), and what Rosen would reply. But there is a lot to consider in regard to his own questions. After all, anticipatory computation would at least pose the following questions:

1. “If this computer were laid out, is there in fact an organized algorithm by which a solution could be laid out, that is, computed?”
2. “Suppose you know this function F_i and it is a function of the variables in the future as well. How would you lay out numbers so that they automatically satisfy the above equation?”

These, again, are Feynman’s words, his own questions. To make it crystal clear: the questions Feynman posed fit the framework of anticipation and computing. However, Feynman was not even alluding to a characteristic of a part of Nature – the living – to be affected not only by its past, but also by a possible future realization. Feynman’s focus was on quantum computation, and therefore the argument developed around probability configurations. When he wrote about simulating a probabilistic Nature by using a probabilistic computer, he realized that the output of such a machine “is not a unique function of the input,” that is, he realized the non-deterministic nature of the computation.

As we shall see, where Feynman's model and considerations on anticipation and computing, related to the work of Rosen and Nadin, diverge is not difficult to define. For him, as for all those – from Aristotle to Newton (*Philosophiæ Naturalis Principia Mathematica*) to Einstein – who made physics the fundamental science it is, there is an all-encompassing Nature, and physics is the science of Nature. In other words, physics would suffice in explaining anticipatory processes or in computationally simulating them.

Svoboda (1960, cf. Klir 2002b) published a “model of the instinct of self-preservation” in which the subject is a computer itself. Its own functioning models self-preservation under external disturbances. A probabilistic description based on inferences from past experiences quantifies its predictive capability. Pelikan (1964) further elaborated Svoboda's original idea. Probably, as we advance in our understanding of anticipation, there will be more contributions that, in retrospect, will deserve our attention. For example, in 1950 (cf. Gabel and Walker 2006) Buckminster Fuller outlined a class in anticipatory design (taught at MIT in 1956). In this class, “Eight Strategies for Comprehensive Anticipatory Design Science” were spelled out. Fuller took a broad view of what it means to introduce new artifacts into reality. There is a lot to consider in terms of how they change the given environment and the behavior of individuals and communities. Teleology, i.e., the goal-driven aspect of design, is to be understood in relation to what he called “precession”: the sequence of steps that lead from the assumed goal (subject to continuous reevaluation) to the end result (itself subject to further improvement).

The American economist Willford Isbell King (at one time Chairman of the Committee for Constitutional Government) published *The Causes of Economic Fluctuations: Possibilities of Anticipation and Control* (1938). The circumstances (in particular the Great Depression) explain the subject and hope. The same title could be used in our days. Fluctuations continue to haunt us, and predictive models developed so far are not very helpful when it comes to avoid dire consequences. At about the same time (1937, actually), George Shackle, under the supervision of Friedrich von Hayek, finished his dissertation, which led to his first book (1938). Expectation, as a particular form of anticipation is connected to his future contributions to defining uncertainty. Let us take note that in examining the time vector from the beginning of an action (threshold) and the time vector from the end of the action in reverse, Shackle noticed that we never have enough knowledge in order to understand the consequences of our actions. Of interest to us today is Shackle's understanding of possibility, and the contradistinction to probability. A short quote is indicative of the anticipation implications of his writing: “It is the degree of surprise to which we expose ourselves when we examine an imagined happening as to its possibility...” (cf. Klir 2002a for an in-depth analysis). As far as I was able to establish, Shackle did not use the word *anticipation*, but he referred to imagination as guiding choices (1979). His conceptual contribution in understanding imagination as related to the space of possibilities will surely lead to more elaborations of interest to research in anticipation.

Possibility and its relation to probability that was of interest to Shackle (cf. 1961) will have to wait for a more comprehensive approach until Lotfi Zadeh (1978), and

subsequently many distinguished followers, gave it a foundation. Zadeh himself arrived at possibility via fuzzy sets. In June (2009a), Zadeh, continuing his tireless investigation of the realm of knowledge he opened when introducing fuzzy sets, made note of the fact that judgment, perception, and emotions play a prominent role in what we call economic, legal, and political systems. Many years ago, Zadeh (1979/1996) invoked the views of Shackle, among others, as an argument in introducing information granularity. This time, acknowledging complexity – which, as we shall see, is the threshold above which anticipatory behavior becomes possible – Zadeh took a look at a world represented not with the sharp pen of illusory precision, but with the spray can (“spray pen geometry”). Where others look for precision, Zadeh, in the spirit in which Shackle articulated his possibilistic views, wants to capture processes unfolding under uncertainty. We realize, at least intuitively, that anticipations (like imagination) are always of a fuzzy nature, and it seems to me that Zadeh’s new work, intensely discussed on the BISC mailing list, will make the scientific community even more aware of this condition.

It is significant that economics prompts the type of questions that unite the early considerations of King (1938) and Shackle (1938) with Klir’s considerations (2002a) and Zadeh’s (Zadeh et al. 2009b) very recent attempts to extend fuzzy logic. Questions pertinent to economics (and associated fields of inquiry) will undoubtedly further stimulate anticipation research. We want to know what the possibilities for success are, or at least what it takes, under circumstances of uncertainty, to avoid irreversible damage to our well-being, and often to society’s.

Where Do We Go From Here?

The knowledge base reflecting the multitude of perspectives from which individual authors proceeded as they pursued the subject of anticipation continues to grow. This is no longer a preliminary stage, although it would be illusory to assume that a well-defined description has been established. Despite the urgency of providing an anticipatory perspective to the fast dynamics of our time, there are no university classes dedicated to it, and no research initiatives specifically informed by this perspective. Everyone hopes for good predictions; money is spent on funding predictive methods, as though prediction could substitute for anticipation. Still, the subject quite often percolates among the many research themes associated in some ways with cognitive science, computer science, artificial intelligence, and even ALife.

With Rosen’s concept of anticipation as a reference, the following consideration will provide pointers to relevant research. A distinction will be made between studies pursuing Rosen’s theoretic outline, and studies defining the field in ways other than his own; or better yet, what he called pseudo-anticipation. No author could claim credit for a full account. We can more easily find what we look for, but at times to formulate the question is more challenging than to advance a hypothesis as an answer. Example: Ishida and Sawada (2004) report on a very simple experiment

of human hand movement in anticipation of external stimulus. Unfortunately, while actually reporting on anticipation, the authors never name the concept as such. (It is from this experience that I discovered how many Japanese scientists would be happy to have access to a new edition of AS.) In other cases, anticipation, the word, is present, but the results presented have actually nothing to do with it. I prefer not to single out an example because, after all, there is nothing to object to in what is presented, but rather to the use of a concept that has had a precise meaning ever since Rosen's AS and other contributions (mentioned in the previous section of the Prolegomena). The fact that the scientific community at large has not embraced the view reflected in Rosen's particular interpretation, or in definitions congruent with his, means only that more has to be done to disseminate the work, in conjunction with its understanding. Einstein's assessment – No problem can be solved from the same consciousness that created it – is relevant not only for those willing to step out from their epistemological cocoon, but also for those who literally cannot find useful answers within the epistemology they practice.

Classical research in psychology – in particular, on receptive-effector anticipation (Bartlett 1951) – prepared the way for perceptual control theory (PCT) initiated by William T. Powers (1973, 1989, 1992) around the notion of organisms as controllers. All this is obviously different from Hacker's work in what used to be the German Democratic Republic. Kelly's (1955) constructivist position is based on validation in terms of predictive utility. Coherence is gained as individuals improve their capacity to anticipate events. Since the premise is that knowledge is constructed, validated anticipations enhance cognitive confidence and make further constructs possible. In Kelly's terms (also in Mancuso and Adams-Weber 1982), anticipation originates in the mind and is geared towards establishing a correspondence between future experiences and predictions related to them. The fundamental postulate of this theory is that our representations lead to anticipations, i.e., alternative courses of action. Since states of mind somehow represent states of the world, anticipation adequacy remains a matter of validation through experience.

Anticipation of moving stimuli (cf. Berry et al. since 1999) is recorded in the form of spike trains of many ganglion cells in the retina. Known retinal processing details, such as the contrast-gain control process, suggest that there are limits to what kind of stimuli can be anticipated. Researchers report that variations of speed, for instance, are important; variations of direction are less significant. That vision remains an area of choice in identifying anticipation is no surprise. An entire conference (University of Dundee, 2003) was dedicated to Eye Movements – considered “a window on mind and brain” – while the European project MindRaces (2009): *from reactive to anticipatory cognitive embodied systems* encouraged studies in this field, given its applied nature (Pezzulo 2007a, 2007b). Balkenius and Johansson (2007) contributed to the project the research of anticipatory models in gaze control, integrating reactive, event-driven and continuous-model-based location of target. Obviously, learning in their view is rather different from Rosen's notion, which predates AI's focus on learning in our days. It is encouraging to notice that the recognition of the role of learning extends to their particular domains of interest.

Arguing from a formalism, such as Rosen used, to existence is definitely different from arguing from existence (seeing, hearing, binding of the visual and aural, etc.) to a formalism. A vast amount of work (concerning tickling, e.g., [Blakemore et al. 1998](#); posture control, e.g., [Gahery 1987](#), [Melzer et al. 2001](#), [Adkin et al. 2002](#)); gait control ([Sahyoun, et al. 2004](#)) exemplifies the latter. In the same category, reference can be made to [König, and Krüger 2006](#) on the subject of predictions about future stimuli (the frog spotting a flying insect, and the process of filling in the informational gap in order to define the position where its tongue will capture it in a swift move). The authors allude to patterns of behavior. Such patterns are also suggested in the research of [Roth \(1978\)](#) as he analyzes the prey catching behavior of *Hydromantes genei*.

The very encouraging aspect in such research is that measurements of trigger-based experiments reveal what happens before the trigger (obviously if the measurement itself is not set off by the trigger). In other words, what happens in anticipation of stimuli (can be guessing, prediction, noise, for example), not as a result of them begins to be examined. Preparation (cf. [Gahery 1987](#)) is part of the anticipatory process. I doubt that a theory of anticipation, or at least some amendments to the available theories, could emerge from these rich sets of data. But such experimental evidence is encouraging first and foremost because it consistently supports the fundamental idea expressed in Rosen's modeling relation: If a modeling relation between a natural system and a formal description can be established, the formal description (of vision processes, of tickling, of tactility, of sound and image binding, etc.) is a model, and the domain knowledge is a realization of such a description subject to further investigation. Moreover, arguing from computation – which is more and more a gnoseological mode – might impress through even broader sets of data and much more detail, but still not substitute for the lack of a theoretic foundation. As impressive as applications in neural networks ([Homan 1997](#), [Knutson et al. 1998](#), [Kursin 2003](#), [Tsirigotis et al. 2005](#)), artificial intelligence ([Ekdahl et al. 1995](#), [Davidsson 1997](#)), adaptive learning systems ([Butz et al. 2003](#)), among others, are, they can at most make us even more aware of the need to define our terminology and practice scientific discipline. [Rosen \(1991, p. 238\)](#) pointed out quite clearly that the more constrained a mechanism, the more programmable it is. Albeit, reaction is programmable, even if at times it is not exactly a trivial task to carry out. Modeling and simulation, which are intensive computational tasks, are no more anticipatory than any other mechanisms. They embody the limitation intrinsic in the epistemological horizon in which they were conceived. Neural networks and anticipation, followed by impressive achievements in animation and robot motion planning ([Balkenius et al. 1994](#), [Christensen and Hooker 2000](#), [Fleischer et al. 2003](#)), only allow us to realize again the difference between purposive activities (where there is a finality; a “final cause”) and deterministic activities, of a different causal condition.

This observation brings up the effort known under the name *CASYS conferences* (organized by Daniel M. Dubois, in Liège, Belgium since 1997). Dubois builds upon [McCulloch, and Pitts \(1943\)](#) “formal neuron” and on von Neumann's suggestion that a hybrid digital-analog neuron configuration could explain brain dynamics

(cf. 1951). It is tempting to see the hybrid neuron as a building block of a functional entity with anticipatory properties. But from the premise on, Rosen followed a different path, quite convincingly, that recursions could not capture the nature of anticipatory processes (since the “heart of recursion is the conversion of the present to the future”). Neither could incursion and hyperincursion (an incursion with multiple solutions that Dubois advanced) satisfy the need to allow for a vector pointing from the future to the present. Rosen warned about the non-fractionability of the “(M,R)-Systems”; and this is of consequence to the premise adopted in Dubois’ work. When Dubois (2000) defines “...the main purpose...is to show that anticipation is not only a property of biosystems, but is also a fundamental property of physical systems,” he argues with Rosen’s fundamental ideas from a position that basically ignores the distinction between the ontological (of which anticipation is a characteristic) and the epistemological. Within science, difference of views is perfectly acceptable, provided that the concepts are coherently defined. This provision is ultimately not met. For particular applications, Dubois’ take is quite convincing. His conference usually serves as a good opportunity for featuring contributions inspired by his work. Addressing issues of autonomous systems (i.e., they self-regulate), Collier (2008) builds on Dubois’ conjecture in addressing autonomy and viability. Suffice it to say that such a contribution is in itself relevant for the richness of the dialog that Rosen’s book and its subsequent interpretations triggered.

Chrisley (2002) is among those aware of the contradictory situation in which proponents of “computing anticipatory systems” are. He is explicit: One can go further and inquire as to the extent to which such causal anticipatory systems are computational. This is very important since, as Chrisley notes, the model is essential, not the data. The so-called “transduction of present data into future data (i.e., into predictions) through the agency of a model of the world “does not turn the probabilistic prediction into anticipations. Indeed, the anticipation, expressed in action, is, after all, part of the system from which it originates. In order to address this aspect, Dubois (2000) distinguished between weak anticipation – more or less along Rosen’s idea of a model-based process – and strong anticipation “when the system uses itself for the construction of its future states,” (Dubois and Leydesdorff 2004). Leydesdorff (a distinguished researcher of social systems examined from an anticipatory perspective) argues that “the social system can be considered as anticipatory in the strong sense,” (it constructs its future). Leydesdorff (2008) further enlarges upon this observation in examining intentionality in social interactions.

Along this line, I want to mention some very convincing attempts to relate perception and motoric response (Steckner 2001) to address issues of predictive model generation (Riegler 2001), to associate anticipation with decision-making processes (Nadin 2009a), to deal with interaction as it results in a variety of anticipatory processes (Kinder 2002). Riegler (2004) focuses on “Who (or what) constructs anticipation?” It is, as he defines it, a challenge to the implicit assumption of Rosen’s model-based definition. The “decision maker” whom he is after remains an open question. In the area of applied interest (automobile driving, assessing the impact of emerging technologies, extreme events assessment, the whole gamut

of applications in the *MindRace* program), authors from various backgrounds (Munduteguy and Darses 2007, Myers 2007, Nadin 2005, Nadin 2007; Pezzulo 2007a, 2007b, Butz 2007, among others) advance cognitive and information processing models that contribute to the current interest in pseudo-anticipatory processes. It is significant that Zadeh (2001, 2003) made the connection between computing with perceptions and anticipation. Ernst von Glasersfeld (1995) framed anticipation in the constructivist theory of cognition. Pribam (2000) considered free will and its relation to the brain as an anticipatory system. Klir (2002b) evaluated the role of anticipation in Intelligent Systems.

More recently, within the same interest in fundamental aspects of the subject, issues related to health have been examined from the perspective of anticipation (Berk et al. 2008, research at the Oak Crest Health Research Institute, Loma Linda, CA). The hypothesis that major neuro-motoric disorders (Parkinson's disease, in particular) are the result of skewed anticipation was advanced in an application to an NIH Pioneer grant (Nadin 2007). In respect to this hypothesis, the issue of time and timescale was brought up (Rosen and Kineman 2004), while brain imaging (Haynes 2008) allowed a very telling visualization of decision-making processes.

Beyond Reductionism

Examples – focused on incipient anticipation or on more recent research in anticipatory systems – are only additional arguments to the Prolegomena addressing the justification for a science of anticipatory systems. Very cognizant of the need for a broad foundation, Rosen often referred to Kant. My own decision to follow the example of Kant's *Prolegomena* was also informed by this fact. Evidence from experiments, which has multiplied beyond what was imaginable during Rosen's life (because today experimentation is richer than ever before), places the subject of anticipation in what Kant called the *apodictic*: certain beyond dispute. But the same holds true for reductionism in physics. Rosen was fully aware of this epistemological conundrum. Accordingly, he tried to justify the legitimacy of a science of anticipation as part of a broader science – that of organisms (the “living sciences” or “life sciences” of our days). There is no doubt that *What is Life?* – characterized as a “Fair Scientific Question” – turned out to be for him the “central question of biology (Rosen 1991, p. 25), and the pinnacle of his entire activity. Physics itself would change on account of our better understanding of life.

One does not have to agree with Rosen's concept. However, judgments about it have little meaning if they do not relate his notion of anticipation to his comprehensive view of the living, including the meaning of experimental evidence. Even with the best intentions – there is no reason to expect anything but integrity in the work of researchers – the error of taking a notion out of its broader context can occur. Recently, as I detailed an example I've given many times, I caught myself in such an error. Indeed, in examining the physics of a stone falling, we will notice

that there is no anticipation possible. We can predict the various parameters of the process. A cat falling is an example of “anticipation at work.” But the sentence, “The same stone, let fall from the same position will fall the same way,” does not automatically translate into “The same cat will never fall the same way;” because the cat, after falling once, will no longer be the same. Over time, stones change as well, in the sense that their physical characteristics change; but the time scale of change in the physical is different from the time scale at which the living changes. Moreover, stones do not learn. The cat after the experience is a different cat, a bit older, and richer in experience. This example illustrates how the measurement aspect, the anticipation aspect (influenced by the experience of measurement), and the overarching understanding of the living (as open, learning, on faster time scale, etc.) are tightly connected.

Within this understanding, life emerges beyond the threshold of complexity. Impredicativity and non-fractionability are related because they describe the living in its unity. Therefore, now that the second edition of Rosen’s AS is available, the reader would be well advised to read it in conjunction with *What is Life?* And with Rosen’s book on Measurement. This is an opportunity that the original readers (in 1985) did not have (at least for six years, until *Life Itself* was published). Only in associating all three books can one derive that kind of knowledge alluded to in Kant’s Prolegomena (*On the possibility of metaphysics*).

In reporting on the rich variety or research directions in anticipation today, I was looking less to finding arguments in favor of discipline and more in the direction of acknowledging variations in the meaning of the concept. Rosen’s strict terminological discipline should, of course, not be construed as a declaration of ownership, or, as we shall see in the final part, as an ultimate truth. My own view of anticipation probably differs from his. Those who have tried to approach issues of anticipation have rarely been aware of each other’s work, and almost never of Rosen’s trilogy. My conversations with quite a number of German, Russian, Czech, Japanese, and some French researchers confirmed that Rosen’s work was hardly known to them as part of a larger view of what life is.

The understanding of anticipatory processes as definitory of the living is shared by a minority of those pursuing the subject. But this is science, always subject to subsequent revisions and re-definitions, not religion or a dogmatic pursuit of pure terminology. It would benefit no one to proceed in an exclusionary manner. Knowledge is what we are about; and in the long run, our better understanding of the world and of ourselves, as expressed in new practical experiences, is the final arbiter. In this sense, it can prove useful to our understanding of Rosen’s contribution and the richness of attempts not aligned with his rigorous science, to shortly acknowledge yet another fascinating scientist whose work came close to some of Rosen’s interrogations: Heinz von Foerster. I was unable to find out whether the two of them met. Von Foerster was associated with the University of Chicago for a while; his Biological Computer Lab at the University of Illinois-Urbana Champaign could not have escaped Rosen’s attention. Moreover, his original writings (in establishing Second Order Cybernetics) definitely caught Rosen’s attention. Von Foerster himself was aware of Rosen’s work and found the subject of anticipation

Fig. 2 Rosen’s model of anticipation

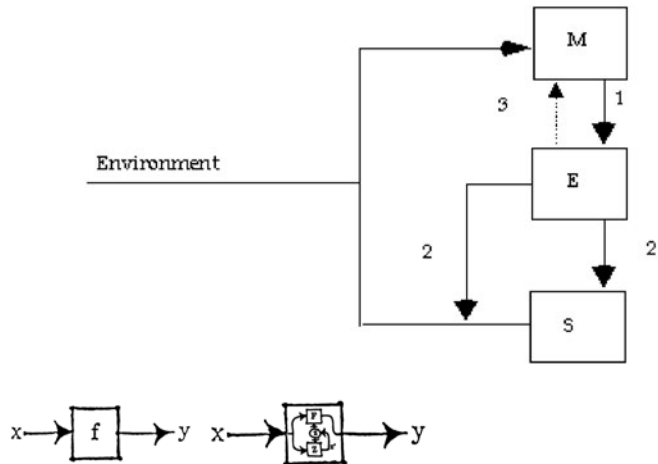

Fig. 3 “Roadsigns Definitions Postulates Aphorisms, etc.,” [sic]. Heinz von Foerster (1995)

very close to his own views of the living and on the constructivist Condition of Knowledge. In his famous formulation, “Die Ursache liegt in der Zukunft” (The cause lies in the future), von Foerster gives what is probably the most concise (or expressive) definition of anticipation. But what prompts my decision to bring up von Foerster is the striking analogy between Rosen’s anticipatory model (1985a, p. 13) and von Foerster’s (2002) concept of non-trivial machines (Figs. 2 and 3).

Let us only make note of the fact that non-trivial machines are dependent on their own history (which is the case with Model M in Rosen’s model), cannot be analytically determined, and are unpredictable (cf. 2002, p. 58).

If the suggestion holds – and we should dedicate more time to it – it is quite clear how from Rosen’s original definition of anticipation many more were derived as alternative, non-trivial, machines (in von Foerster’s sense). This brings up important epistemological questions, such as hybrid computation (the human being or a living entity connected somehow to computers), or even quantum computation in the sense Feynman defined it; interactive computation, membrane computations, DNA computation. It is necessary to realize that we are focused on non-algorithmic data processing, sometimes combining analog and digital representations. Howard Pattee, Rosen’s colleague at the Center for Theoretical Biology in Buffalo – and with whom he had many passionate discussions – still cannot accept Rosen’s intransigence in dealing with von Neumann’s universal constructor – a construct that could achieve unlimited complexity. Pattee is willing to concede that formally von Neumann’s model was incomplete. But he argues that ultimately, von Neumann and Rosen agreed (“life is not algorithmic”), moreover, that self-assembly processes characteristic of the living do not require complete genetic instructions. The reason I bring up this point is rather practical, and Pattee (2007) expressed it convincingly: we should avoid getting diverted from Rosen’s arguments only because, at times, they do not conform with the accepted notions (in this case, von Neumann’s replication scheme).

Rosen (1966) was firmly opposed to von Neumann's understanding that there is a "threshold of complexity" that can be crossed by finite iterations (analogous to the notion that infinity can be reached from a finite number, simply by adding one more). Rosen brought up the need to account for the characteristics of the organism as evolvable, adaptive. Nevertheless, in hindsight we can say that both realized, although in different ways, that if complexity is addressed from an informational perspective, we end up realizing that life is ultimately not describable in algorithmic terms. Chu and Ho (2006) noticed that in Rosen's view, "living systems are not realizable in computational universes." – whatever such computational universes might be. They provided a critical (negative) assessment of Rosen's proof, which Louie (2007) convincingly refuted. Louie's argument in some ways confirms that non-algorithmic self-assembly (epigenetic progresses) is of such a condition that it does not require full descriptions either of the functions or of the information involved in living processes.

Computation and Anticipatory Processes

Given the implications of this observation, let us take a closer look at what it means. Along the line of the Church-Turing thesis – i.e., that every physically realizable process is computable – von Neumann (1963, p. 310) went on out a limb and stated, "You insist that there is something a machine cannot do. If you will tell me precisely what it is that a machine cannot do, I can always make a machine which will do just that." If von Neumann was convinced that telling *precisely* what it is a machine cannot do – emphasis on *precisely* – is a given, he was not yet disclosing that *telling precisely* might after all require infinite strings, and thus make the computation to be driven by such a description impossible (*intractable*, in computer science lingo). It is easy to show that if you completely map a process, even the simplest computation can reproduce its function. But can we completely map even simple biological functions? And given the fact that "To live is to change" (cf. Chorda 2010), to map completely is, in the final analysis, to create a *living representation*, a virtual process in which *matter* is replaced by *information*. Actually, von Neumann should have automatically thought of Gödel (and maybe he did) in realizing that a complete description, which would have to be non-contradictory, would be impossible. Descriptions, in words (as he expected, cf. "anything that can be completely and unambiguously put into words..."), or in some other form (e.g., numbers), are, in the final analysis, semiotic entities. They stand as signs for something else (the represented), and in the process of interpretation they are understood as univocally or ambiguously defined (Nadin 1991).

Representations of the world are always incomplete; they are not fragments of the world. It is such incomplete representations that are processed in an algorithm-driven computation or in some non-algorithmic computational process. Until the development of brain imaging, we could not capture the change from sensorial

energy to the cerebral re-presentational level. And even with images of the brain, semiotic processes are still not quantified. What is quantified are information processes, because information was conveniently defined in relation to energy (cf. [Shannon and Weaver 1949](#)). And we are able to measure energy quite precisely. But meaning is more than information; things make sense or not, not on account of bits and bites, but rather on qualitative changes. It is the re-presentation of things, not things themselves, that is subject to processing and understanding. Re-presentations (like a picture of a stone, or its weight, or the chemical formula/formulae describing its composition) are renewed presentations (of the stone) as signs, which means: dematerialized, extracted from the thermodynamic context, from the dynamics in which they are involved. Interpretations are attempts to associate a sign (a semiotic entity) to an object (a physical entity) and to conjure the consequences that the sign might have on our activity. Re-presentations can be of various degrees of ambiguity – from very low (indexical signs, as marks left by the object represented) to very high (symbols, i.e., conventions). Lightning arouses a sense of danger associated with phenomena in the world. The black cat can bring up false associations (superstitions) with dangers in the world. They are of different levels of ambiguity. The living can handle them quite well, even if, at times, in a manner we qualify as irrational (cf. [Dennett 1991](#) on anticipation).

Machines operate also on representations. But if we expect a certain output – such as the visualization of a process, or the processing of a matrix (a mathematical entity that does not correspond to processes in the world) – we have to provide representations that are unambiguous. Machines do not *dis-ambiguate* representations. For this reason, we conceive, design, and deploy artificial languages of no or very low ambiguity. The living operates, most often effectively, with representations regardless of their ambiguity. The machine is “protected” from ambiguity. (We endow machines with threshold identifiers: is the ignition turned on or not? Neither intermediate values nor intentions count! Ambiguity would be a source of error in their functioning.) Von Neumann’s claim that he could conceive a computation for any *precisely* described entity (i.e., complete description) means nothing more than that he proceeds to segregate between the semiotic of the unambiguous and the semiotics of ambiguity. In von Neumann’s thinking, to be precise means to be also unambiguous (in addition to reducing the measurement error to zero).

Moreover, computational reductionism does not acknowledge the fundamental role of time in the dynamics of the living. Time is reduced to interval. There is a clock that keeps track of sequential processes; and a clock is necessary in order to support the rigid synchronicity of parallel computation. It has been repeatedly demonstrated that an anticipatory system has at least two clocks, i.e., correlated processes unfolding at different times scales ([Nadin 2009b](#)). At various levels of the living, several clocks are at work: some very fast (at nanosecond speed); others in the domain of the “gravitational” clock; and yet others are very slow. Therefore, Rosen’s model unfolding at faster than “real time” is probably a distributed anticipatory process with many models operating at various time scales. [Rosen and Kineman \(2004\)](#) examine the characteristics of complexity in (Robert) Rosen’s view, realizing

correctly the central role played by the modeling relation. “The internal predictive models” are, in their view, hypotheses about future behavior. Finally, Feynman’s understanding of the integration of past, present, and future in the computation (meant to simulate Nature) is probably closer to Rosen’s understanding of anticipation than is von Neumann’s implicit anticipatory dynamics.

With all these considerations in mind, the reader of AS in its second edition should now be in a better position to understand that at the level of algorithm-driven machines (digital or not), anticipation is not possible. Such simple machines operate in the interval domain of causes and effects, in a non-ambiguous manner. As [Verbos \(2010\)](#) noticed, “The brain possesses a kind of general ability to learn to predict.”

Rosen – and not only Rosen (even von Neumann, cf. [Pattee 2007](#)) – ascertained that the living is not representable through a computational process. There are good reasons to accept that the living is not reducible to a deterministic machine, no matter how sophisticated such a machine might be. As we have seen with Feynman’s take on quantum computation, the situation changes: this is qualitatively a different machine; it is a *sui generis* process. Actually, quantum mechanics as a construct originates in response to the deterministic view of nature. Therefore, the argument that a quantum type of computational process can represent life is somehow circular: the quantum representation was constructed in order to overcome the limitations inherent in the classical deterministic concept of machines. The same holds true for DNA computing.

Be this as it may – and with the warning that such discussions cannot be relegated to well-intentioned half-baked scientists (cf. [Penrose 1989](#)) – the question to be posed is, after all, not whether we can ever come up with machines that are not machines in the sense propagated since Descartes (and de la Mettrie), but rather: If enough computational resources are available – theoretically an inexhaustible amount – wouldn’t the aggregate computation be sufficient to become a “life-like” process? Brute force computation – the relatively common practice in almost all instances of computation used to deal with complicated processes – means to throw as many computing cycles as possible at a problem and to work on as much data pertinent to the problem as we can get. IBM’s Deep Blue, which beat Kasparov in a chess game, met Turing’s test of intelligence without even being close to a living chess player (master or beginner). Seemingly, Venter’s attempt at modifying life is also one based on brute force. While [Hacker \(1978, 2005\)](#) addressed anticipation (properly defined as *Vorwegnahme*, the German word that describes *antecipare*, the Latin word behind *anticipation*) in relation to trajectory evaluation – a frog catching prey is the classic example – the *Star Wars* effort was supported by brute force computation. *Star Wars* was not about anticipating an attack, rather integrating information (descriptions of attack circumstances) and providing a reaction based on the fact that the speed of even the fastest ballistic missiles, carrying nuclear warheads or other lethal charge, is limited, and lower than the speed of electrons. If a system can get information as close as possible to the launch pad, given the fact that there is a huge difference in speed between the missile’s movement and the propagation of information, it can generate predictive models and effectively target – like the frog catching an insect – the trajectory load. “Elementary, my dear Watson” – nothing more to add.

With all this in mind, the methodological question becomes: Is the non-algorithmic, or even the broader (ill-defined) non-computable, corresponding to a level of complexity beyond the threshold defining the living, equivalent to infinite computation? The characteristics of powerful computation of large amounts of data (which is the tendency in our days) and the characteristics of brute-force computation (on a larger scale) of small but appropriately selected data are different. Can we evaluate the difference between computing an infinite amount of data (all that we can get given the progress in sensor technology) and the infinite computation needed to process a small but relevant amount of data? Evidently, to know beforehand which data are significant is a matter of anticipation; and it might simply move the problem of computing anticipation from processing all available data to filtering what is significant.

In general, to represent life is to represent something that is in process, changing all the time. For better or worse, we can model/represent – ergo prevent – every oil spill that has already occurred, but not anticipate accurately the one that will happen next. We can similarly model/represent every terrorist attack, and every financial crisis, and every epileptic seizure that have already taken place, but not predict accurately new occurrences of the same. But since there are no laws that capture the uniqueness of extreme events, of disease, of art creation, of Shakespeare’s writings, of scientific research, we cannot build a machine – similar to cars, rockets, AI-driven surgery, etc that will anticipate such things. The regular, patterned, and repetitive can be described as infinite representations. Therefore, machines can be conceived to effectively process such representations. The unique is the subject of idiographic knowledge, which is focused on the particular, not the general. Currently, more and more science is idiographic: visualizations are not abstractions equivalent to mathematical equations. To generalize from an individual’s brain image to all brains is more a matter of faith than of science. Dynamic visualizations – i.e., “films” of certain processes – are even less so. They qualify rather as “histories” – which is the substance of biology – than as “theories.”

Anticipation, always expressed in action, is unique. Repetitive patterns, such as the frog’s behavior in chasing a moving target (and in nature, this is not an exception), or mating behavior, do not result in laws, but in “chronicles” of successful and less successful actions. In ascertaining the action as expression of anticipatory processes, we implicitly ascertain realization at the pragmatic level, but not syntactic or even semantic performance, as is the case with machines. A computation “aware” of its state is an intentional procedure. Such a teleological computation, if we could conceive of it, would have a sense of purpose. It would also be an adaptive computation. Not unlike an artist, who never knows when the goal has been reached (for that matter, every work of art is open, i.e., unfinished), such a computation could also be seen as open-ended. Anticipatory computing (cf. [Nadin 2010b](#)), as a subject, will benefit from Rosen’s many elaborations on the subject, in the sense of terminological coherence.

Once we reach the notion of complexity at which causality itself is no longer reducible to determinism, and the condition of the living integrates past, present, and future, a new form of adaptive behavior and of finality (*purposiveness*) emerges. In

the dimension of complexity, anticipatory processes become possible, although only as non-deterministic processes (after all, anticipation is often wrong (cf. [Dennett 1991](#))).

Life is process (to recall Whitehead, among others), more precisely, non-deterministic process. This makes the role of the physician, and of the economist and the politician, for that matter, so difficult. There is so much science that such endeavors are built upon. But there is always a whole lot of art that makes them successful. Therefore, in addressing causality in respect to the living (a person's health, the state of the economy, the politics associated with managing extreme events), we need to consider past and present (cause-effect, and the associated reaction), both well defined, in conjunction with creativity, i.e., a possible future realization, ill defined, ambiguous. When we have to account for higher complexity – the threshold beyond which reaction alone can no longer explain the dynamics – the anticipatory component must be integrated in our understanding. In logic ([Kleene 1950](#)) an impredicative definition is one in which the definition of an entity depends on some of the properties of the entities described. The definition of life is an example of *impredicativity*; that is, it is characterized by complexity, which in turn is understood as a threshold for the living. If this strikes you as circular, that's because it is. Impredicative definitions are circular. [Kerrel \(2007\)](#) noticed that ambiguity is an observable signature of complexity. He goes on to connect this to the issue of prediction: "Ambiguity of complexity shows that the 'unpredictable' behaviors of complex systems are not random, but are causally determined in a way that we (having no largest model of them) cannot completely predict." These words describe anticipatory dynamics.

Laws of Nature vs. Expressiveness. Generality vs. Singularity

At some moment in the research upon which these Prolegomena are based, I contacted several scientists known to have studied Rosen's work, some who even worked with him. In general, regardless of whether they agreed with his work or were critical of it, the attitude has been one of sincere respect. As radically new as Rosen's perspective was, it was based on a broad intellectual foundation. The fact that he answered questions that nobody else seems to have posed does not make those questions less relevant. Indeed, researchers and scholars from all fields of endeavor and who are captive to an accepted framework tend to function only within the premises they have accepted. Rosen questioned the premises. This was radical. An answer from one of the persons I contacted is telling: I have my reservations about LI, but I fully agree with AS [paraphrase mine].

How can this be? This question is prompted by the subject of the Prolegomena: What speaks in favor of an inquiry into anticipatory processes? In simpler terms: Will the time come when we go to a store and buy not only an iPhone or an iPad, but also an iAnticipator? It is easy (and comes close to demagoguery) to consider the most recent crises – financial meltdown, slowdown in the economy,

ash clouds from volcanoes, oil spills in the Gulf of Mexico – and exclaim: We need anticipation! The French speak about *le grand soir* (the great evening) – that would be the “evening” when we will know everything about what will happen and either avoid it (somehow), or at least prepare for it. That would mean the miraculous cure, the gene switch that we only have to put in the right position in order to cure cancer; no more stock market crashes, no more disastrous oil spills, etc. etc. Animated by an optimism that is implicit in every scientific endeavor, many talented and very serious scholars are trying to make such a *grand soir* happen. They believe in determinism. If it happens, there must be a cause behind it. The advent of the information revolution made membership in the holy dogma of reductionist determinism easier. These scholars and researchers are willing to concede that the short sequence of cause-and-effect might be an oversimplification, and then, since they have access to information processing, chase after longer and longer sequences. All kinds of systems, using computation as their underlying procedure or not, are conceived for a variety of reasons: to help prevent terrorist attacks, stock market crashes, pandemics, etc. Other systems are deployed for automating tasks involving a great deal of uncertainty: from nuclear power plant monitoring to autonomous airplane piloting, or even autonomous automobile driving. Finally, others go so far as to create new realities, where functioning according to such deterministic rules is implicit in their making. The clock of the remote past serves as the “universal” blueprint; the hardware was conceived as a sequence of cause-and-effect mechanics.

Synthetic life – yet another example of a knowledge domain rapidly ascertaining itself – is exactly what I am referring to. But where *Fabrication of Life*, which is part of the subtitle of Rosen’s LI, I interpret as “how life fabricates its own life,” synthetic life is the attempt – deserving our entire respect as a scientific goal – to create life from non-life on the basis of a cause-and-effect understanding of the living. All these attempts are based on the assumption that laws similar to those of physics (if not the same laws) can be formulated and applied in order to construct anticipatory machines or living machines with the same degree of success that humankind has already had in building cars, airplanes, rockets, computers, self-assembling nano-machines, and the like.

My own position on the matter is very clear: laws of physics or quantum mechanics fully apply to the physical aspects of the living, but not to its specific dynamics. Complexity is not the result of additive physical processes. Very recently, Kauffman and Longo came out with similar conclusions, in line with Rosen’s view of the living: No law entails the evolution of the biosphere (Kauffman and Longo 2011). Kauffman (2011) dedicated a lecture to “The end of physics as a world view.” Neither Kauffman nor Longo referred to anticipation; but sooner or later they will have to integrate it in their arguments leading to their sweeping assertions.

Readers of *AS* will understand that this book, even in its revised version, is not a *How to* manual, but rather a *Why?* inquiry into what makes anticipation a characteristic of the living. Could Rosen have put together an “Anticipatory Systems for Dummies” in the vein of all those “4 Dummies” books written with the aim of making us all better mechanics, plumbers, graphic designers, gardeners, users of word-processing programs, etc? First and foremost, that would not have been a task

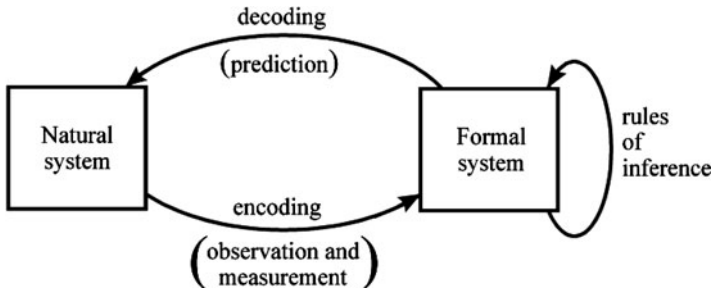

Fig. 4 Initial modeling relation

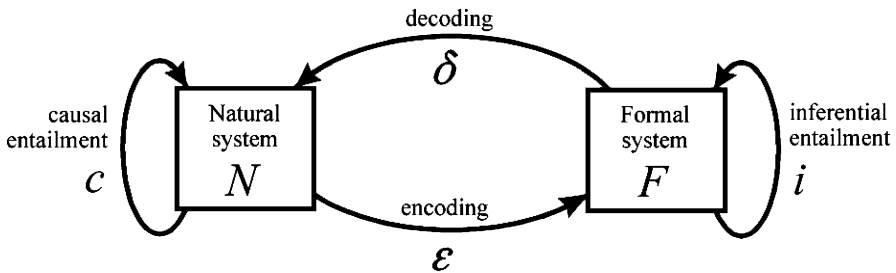

Fig. 5 Revised modeling relation

for a passionate intellectual who was fully committed to his science. Moreover, neither what defines the living nor what it means to measure, and even less what anticipation is are subjects for the do-it-yourself obsession of our time.

For something to be replicated, we need the understanding of what is needed for that entity to exist in the first place. Rosen expressed this kind of understanding in the modeling relation. This is, in a very concentrated form his epistemology (Fig. 4).

In AS, the natural system is represented by a formal system: knowledge is derived as inference and eventually guides practical activities. Rosen explains: Knowledge acquisition translates as an attempt to encode natural systems (i.e., represent them based on a semiotic code) into formal descriptions (equations, diagrams, etc.). Operating on representations, we can derive inferences or even theorems (statements that can be finally proven). Such operations eventually result in statements about how the natural system might behave. In fact, a modeling relation is, *in nuce*, a “theory of prediction.” For it to become a “theory of change,” (cf. Nadin 2010d), it would have to account for how the natural system behaves over time. Causality – causal entailment, in Rosen’s original thought – is the answer to the *Why?* question definatory of relational biology. In LI, causality is expressed as causal entailment and “rules of inference” are seen as the causal entailment encoded into inferential entailment, which completes the modeling relation diagram (Fig. 5).

Anticipation itself has the condition of entailment. It is clear that there is anticipation in the natural system; but this does not translate, in a one-to-one

relation, into the formal system, and even less into the ability to replicate it. In his words:

We seek to encode natural systems into formal ones [such that] the inferences or theorems we can elicit within such formal systems become predictions about the natural systems we have encoded into them (p. 74 of the original edition).

If we associate Rosen's clear statement with Einstein's (1921) observation, "In so far as the propositions of mathematics are certain, they do not apply to reality; and in so far as they apply to reality, they are not certain," we realize that only charlatans can promise to deliver a known future event. What is possible, however, is the design of systems that allow us to consider under which circumstances our descriptions of reality will have to be endowed with adaptive properties (no matter how primitive or limited in scope).

Earlier in the Prolegomena, the point was made that hyperboles do not help us better understand Rosen's original contributions. Beyond the hyperbole in "Biology's Einstein" lies an argument we need to consider: Rosen advanced a coherent view of the living within a broad understanding of what is traditionally called Nature. If in respect to the physical, the formal system allows us to infer laws, on the basis of which machines are built, then in respect to the living, we can at best describe successions, and further relations between the events or phenomena succeeding each other. Windelband (1894), who advanced the distinction between *noematic* sciences (focused on descriptions in the forms of laws) and the *idiographic* sciences (focused on descriptions of sequences, in the form of Gestalt), would have mentioned Rosen's view as illustrative of both (if he had not been his precursor by almost a century). Rosen specifically spells out (*LI*, p. 58) that science describes the world ("that is in some sense orderly enough to manifest relations or laws"), but that it also "says something about ourselves." The "orderliness" of the world (ambience) "can be matched by, or put into correspondence with, some equivalent orderliness within the self." This is what makes science, and also the scientist, possible.

What speaks in favor of an inquiry into anticipatory processes is the need to ascertain the complementarity of noematic and idiographic knowledge. Every process of anticipation, definitory of the natural system, involves knowledge as an expression of accumulated experience, but also of art as an expression of the creativity implicit in the living. In a very telling private communication (addressing Segel, who reviewed "Organisms as causal systems which are not mechanisms: an essay into the nature of complexity"), Rosen (1985c) uses a very intuitive image: "The point of view I have taken over the past 25 years is that the way we look at systems is no different than the way we look at each other . . . dynamic interactions between the (systems) are cognate to our own observing process." His intention in explaining his view to a colleague who "did not get it" (as we would say today) was very simple: "I'm writing the above only so that we may understand each other better." This second edition of AS is a delayed "letter" to a new generation of scientists who are now in a better position than Rosen's own generation to entertain provocative ideas that justify current interest (and hope) in anticipation studies.

Final Note

Rosen wanted to write a book on complexity. Many scholars and researchers wish he did. It was not to be; but it suggests to the scientific community that progress in understanding the relation between complexity and anticipation requires that we define the situation at which anticipation becomes possible – and probably necessary.

Science is not about doctrine – even less about faithfulness. Rosen’s work should therefore not be seen in a light different from his own: It is yet another hypothesis – probably one whose time has finally come. In publishing a second edition of *AS*, those involved in the process did not intend to suggest a return to the initial book, rather to stimulate further dialog and more probing scientific investigation. Judith Rosen has her own well-defined identity; she is also passionate about her father’s legacy and understands why dialog is important. She never hesitated in providing answers to questions I had or volunteering details I would not have access to. George Klir is dedicated to this book, and even more to the pursuit of academic dialog of integrity. A.H. Louie, who has also supported the effort of seeing a second edition of *AS* published, disseminates Rosen’s thoughts in his own distinguished publications. His teacher would have been proud of him. I have benefited from their competence and wisdom, and I admire their knowledge and appreciation of Rosen’s ideas. I also benefited from contacts with Peter Cariani, Roy Chrisley, Winfried Hacker, G. Hoffman, S. Kerckel, Dobilas Kirvelis, Andres Kurismaa, Loet Leydesdorff, Helmut Loeckenhoff, Alexander Makarenco, E. Minch, H.H. Pattee, Dean Radin, Marion Wittstock (who made me aware of the work of the Dresden group), and Olaf Wolkenhauer, and want to express my gratitude for their help. In particular, my respect to Lotfi Zadeh for some very useful conversations, and to Otthein Herzog for making possible my research at the Information Technology Center (TZI, Bremen University, 2009–2010). Lutz Dickmann was a patient sounding board for many of my hypotheses. He challenged me in the spirit of his own research for his Ph.D. To what extent my research of anticipation enriched the work of everyone I interacted with (in the project Anticipation-Based Intelligent Multiagent Societies for Logistics) remains to be seen. A Fellow award at the Hanse Institute for Advanced Study (Delmenhorst, Germany) allows me to focus on the relation between anticipation and its representation. A first concrete result is the study dedicated to the expression of anticipation in innovation (Nadin 2012c) and the interaction I had with a distinguished musician (Tibor Szász, Freiburg) regarding anticipation expressed in musical creativity (in particular Enescu and Bartók). But this was also a time for putting the finishing touches on these Prolegomena. Publication of the second edition of *AS* does not do any favor to Rosen – his work stands on its own – but to everyone who is authentically interested in the subject. My prediction is that the book will stimulate more attempts to integrate the anticipatory perspective in our understanding of the world.

References

- Adkin, A.L., *et al.* (2002). Fear of falling modifies anticipatory postural control. *Experimental Brain Research*, 143(2), 160–170.
- Alink, A., *et al.* (2010). Stimulus predictability reduces responses in primary visual cortex. *Journal of Neuroscience*, 30(8), 2960–2966.
- Ashby, W.R. (1956). *An introduction to cybernetics*, London: Chapman & Hall.
- Balkenius, C., Kopp, L., Pallbo, R. (1994). A robot with autonomous spatial learning: a project overview. In R. Sillen (Ed.), *Proceedings of SAIS 94*. Ronneby: Nova Cast.
- Balkenius, C., & Johansson, B. (2007). Anticipatory models in gaze control: a developmental model. *Cognitive Processing*, 8, 167–174.
- Bartlett, F.C. (1951). *Essays in psychology*. Dedicated to David Katz. Uppsala: Almqvist & Wiksells, pp. 1–17.
- Berk, L., Tan, S.A., Berk, D. (2008). *Cortisol and catecholamine stress hormone decrease is associated with the behavior of perceptual anticipation of mirthful laughter*. American Physiological Society (April 10). See also: Anticipating A Laugh Reduces Our Stress Hormones, Study Shows. *ScienceDaily*. <http://www.sciencedaily.com/releases/2008/04/080407114617.htm>. Accessed 2 Nov 2008.
- Bernstein, N.A. (1924). Trouvye tranirovki I uslovnnye refleksy [Work movements and conditioned reflexes]. *Organizatsiia truda* 84.
- Bernstein, N.A. (1935). Das Problem der Wechselbeziehungen zwischen Koordination und Lokalisation [The problem of the interrelationships between coordination and localization]. In L. Pickenhain and G. Schnabel (Eds.). *Bewegungsphysiologie von N.A. Bernstein* (2nd ed., pp. 67–98).
- Bernstein, N.A. (1936). *Sovremennye iskaniia v fiziologii nervnogo protsessa* [Contemporary research on the physiology of the nervous system]. J. Feignberg and I. Sirotkina (Eds.). Moscow: Smysl.
- Bernstein, N.A. (1947). *O postroenii dvizhenii* [On the construction of movements]. Moscow: Medgiz.
- Bernstein, N.A. (2004). Put' I zadachi fiziologii aktivnosti. *Biomekhanika I fiziologiia dvizhenii*. Moscow and Voronezh: Rossiiskaia Akademiia obrazovaniia, Moskovskii psihologosotzial'nyi institute (pp. 448–480). See also: Paths and tasks of the physiology of activeness (S.D. Shenfield, Trans.). *Journal of Russian and East European Psychology*, 44:2, March–April 2006 (pp. 33–59).
- Berry, M.J., *et al.* (1999). Anticipation of moving stimuli by the retina, *Nature*, 398, 334–338
- Bertalanffy, L.v. (1968). *General system theory: foundations, development, applications*, New York: George Braziller.
- Blakemore, S.J., Wolpert, D.M., Frith, C.D. (1998). Central cancellation of self-produced tickle sensation. *Nature Neuroscience*, 1(7), 635–640.
- Butz, M., Sigaud, O., Gérard, P. (Ed.) (2003). *Anticipatory behavior in adaptive learning systems: foundations, theories, and systems*. Berlin: Springer.
- Butz, M.V., *et al.* (Ed.) (2007). *Anticipatory behavior in adaptive learning systems. from brains to individual and social behavior* (Lecture Notes in Computer Science and Lecture Notes in Artificial Intelligence) (p. 4520). Berlin: Springer.
- Chorda, F. (2010). *Vivir es Cambiar* (To Live is to Change). Barcelona: Anthropos.
- Chrisley, R. (2002). Some foundational issues concerning anticipatory systems. In D.M. Dubois (Ed.), *International journal of computing anticipatory systems* (pp. 3–18).
- Christensen, W.D., & Hooker, C.A. (2000). Anticipation in autonomous systems: foundations for a theory of embodied agents. *International Journal of Computing Anticipatory Systems*, 5, 135–154.
- Cohen J.E. (1971). Mathematics as metaphor. *Science*, 172, 674–675
- Collani, E.v. (2006). Jacob Bernoulli Deciphered. In *Newsletter of the Bernoulli Society for Mathematical Statistics and Probability*, 13(2), 229.

- Collier, J. (2008). Simulating autonomous anticipation: the importance of Dubois' conjecture. *Biosystems*, *91*, 346–354.
- Davidsson, P. (1997). Learning by linear anticipation in multi-agent systems. *Distributed Artificial Intelligence Meets Machine Learning. Learning in Multi-Agent Environments. Lecture Notes in Computer Science* (pp. 62–72) Berlin: Springer.
- Dennett, D.C. (1991). *Consciousness explained*. New York: Little Brown.
- Dubois, D.M. (2000). Review of incursive, hyperincursive and anticipatory systems – foundation of anticipation in electromagnetism. In D.M. Dubois (Ed.), *Computing Anticipatory Systems CASYS'99* (pp. 3–30). New York: AIP Proceedings.
- Eilenberg, S., & MacLane, S. (1945). Relations between homology and homotopy groups of spaces. *Annals of Mathematics*, *46*, 480–509.
- Eilenberg, S., & MacLane, S. (1950). Relations between homology and homotopy groups of spaces, II. *Annals of Mathematics*, *51*, 514–533.
- Einstein, A. (1921). *Geometrie und Erfahrung*. Berlin: Springer. Einstein's essay is an expanded form of an Address to the Prussian Academy of Sciences in Berlin on January 27, 1921.
- Ekdahl, B., Astor, E., Davidsson, P. (1995). Toward anticipatory agents. In: M. Woolridge, N.R. Jennings (Ed.), *Intelligent agent – theories, architectures, and languages, lecture notes in artificial intelligence* 890 (pp. 191–202). Berlin: Springer.
- Elsasser, W.M. (1958). *The physical foundation of biology*. New York: Pergamon.
- Elsasser, W.M. (1966). *Atom and organism*. Princeton: Princeton University Press.
- Elsasser, W.M. (1975). *The chief abstraction of biology*. Amsterdam: North Holland.
- Elsasser, W.M. (1977). *Memoirs of a physicist in the atomic age*. Sagamore Beach: Watson.
- Elsasser, W.M. (1987, 1998). *Reflections on a theory of organisms*. Freilighburg Editions Orbis, 1987, (reprinted by Johns Hopkins University Press in 1998).
- Feynman, R.P. & Hey, A.J.G. (1999) *Feynman Lectures on Computation*. Boulder CO: Westview Press (New York: Perseus Books).
- Fleischer, J., Marsland, S., Shapiro, J. (2003). Sensory anticipation for autonomous selection of robot landmarks. In M. Butz, O. Sigaud, P. Gerard (Ed.), *Anticipatory behavior in adaptive learning systems: foundations, theories, and systems* (pp. 201–221). Berlin: Springer.
- Foerster, H.v., & Poersken, B. (2002). *Understanding systems: conversations on epistemology and ethics*. K. Leube, trans. New York: Kluwer Academic/ Plenum.
- Fuller, B. (1956). Eight strategies for comprehensive anticipatory design science. <http://bfi.org/design-science/definitions-and-resources/eight-strategies-comprehensive-anticipatory-design-science>. Accessed 6 June 2009.
- Gabel, M., & Walker, J. (2006). Leadership by design: how one individual can change the world. The leadership principles of Buckminster Fuller. *Futurist*, *40*(5), 39–44.
- Gahery, Y. (1987). Associated movements, postural adjustments and synergy: some comments about the history and significance of three motor concepts. *Archives Italiennes de Biologie*, *125*, 345–360.
- Galperin, P.I. (1967). Die geistige Handlung als Grundlage für die Bildung von Gedanken und Vorstellungen. In *Probleme der Lerntheorie*, Berlin.
- Ginzburg, L. (1986). *BioScience*, *36*(10), 692.
- Glaserfeld, E.v. (1995). *Radical constructivism: a way of knowing and learning*. London: Falmer.
- Hacker, W. (1978). *Allgemeine Arbeits- und Ingenieurpsychologie* (General Labor and Engineering Psychology). Bern/Stuttgart/Vienna: Verlag Hans Huber.
- Hacker, W. (2005). Vorwegnahme der Bewegungsbahn (Anticipation of Trajectory). In *Allgemeine Arbeitspsychologie* (pp. 620–629). Bern: Huber.
- Haynes, J.D. (2008). Detecting deception from neuroimaging signals: a data-driven perspective. *Trends in Cognitive Science*, *12*, 126–127.
- Homan, C. (1997). Beauty is a rare thing. http://www.cs.rochester.edu/users/faculty/dana/csc240_Fall97/Ass7/Chris_Homan.html. Accessed 7 April 2009.
- Ishida, F., & Sawada, Y. (2004). Human hand moves proactively to the external stimulus: as evolutionary strategy for minimizing transient error. *Physical Review Letters*, *93*(16), 15.
- Kant, I. (1781). *Critique of Pure Reason (Kritik der reinen Vernunft)*

- Kant, I. (1783). *Prolegomena zu einer jeden künftigen Metaphysik*. Riga: bey Johan Friedrich Hartknoch. (See also: *Prolegomena To Any Future Metaphysics That Will Be Able To Present Itself as a Science*. Indianapolis, New York: Bobbs-Merrill Co. 1950).
- Kant, I. (1788). *Critique of Practical Reason (Kritik der praktischen Vernunft)*
- Kant, I. (1790). Critique of Judgment or The Critique of the Power of Judgment (Kritik der Urteilskraft). In G. Hartenstein (Ed.), *Immanuel Kants Werke in zehn Bänder*, Leipzig: Modes und Baumann.
- Kauffman, S. (2011). The end of a physics worldview: Heraclitus and the watershed of life (a lecture developed in collaboration with G. Longo). New England Complex Systems Institute (NECSI) and the Massachusetts Institute of Technology/Engineering Systems Division (MIT/ESD) Seminar, October 19, 2011, Cambridge MA. See also <http://necsi.edu.video.kauffman.html>. Accessed 20 November 2011.
- Kauffman, S., & Longo, G. (2011). No law entails the evolution of the Biosphere. Computational Systems Biology Research Group, Tampere University of Technology, Finland, July 8, 2011. See also [http://csb.cs.tut.fi/no.law.entails.the-evolution.of.the.biosphere.php](http://csb.cs.tut.fi/no.law.entails.the.evolution.of.the.biosphere.php). Accessed 11 November 2011.
- Kelly, G.A. (1955). *The psychology of personal constructs*, New York: Norton.
- Kercel, S. (2002). Endogenous causes – Bizarre effects, *Evolution and Cognition*, 8(2), 130–144.
- Kercel, S. (2007). Entailment of ambiguity. *Chemistry and Biodiversity*, 4(10), 2369–2385.
- Kinder, E. (2002). When Everybody anticipates in a different way. In D.M. Dubois (Ed.), *Proceedings of the 5th Conference on Computing Anticipatory Systems, CASYS'01* (119–127). New York: AIP Conference Proceedings.
- King, W.I. (1938). *The causes of economic fluctuations: possibilities of anticipation and control*. New York: Ronald.
- Kleene, S.C. (1950). A symmetric form of Gödel's theorem. In: *Proceedings of the Koninklijke Nederlandse Akademie van Wetenschappen. Series A, Mathematical Sciences*, 53, 800–802 [and In: *Indagationes Mathematicae*, 12, 244–246].
- Klir, G.J. (2002a). Uncertainty in economics: The heritage of G.L.S. Shackle, *Fuzzy Economic Review*, VII(2), 3–21.
- Klir, G.J. (2002b). The role of anticipation in intelligent systems. In D.M. Dubois (Ed.), *Proceedings of the 5th Conference on Computing Anticipatory Systems, CASYS'01* (pp. 37–58). New York: AIP Conference Proceedings.
- Knutson, B., Westdorp, A., Hommer, D. (1998). Functional neuroanatomy of approach and active avoidance using fMRI. *NeuroImage*, 7, 918.
- König, P., & Krüger, N. (2006). Symbols as self-emergent entities in an optimization process of feature extraction and predictions. In: *Biol. Cybern* 94 (pp. 325–334). Heidelberg: Springer.
- Kursin, A. (2003). Neural network: Input anticipation may lead to advanced adaptation properties. *Artificial Neural Networks and Neural Information Processing – ICAN/ICONIP*, 2714, 779–785.
- Leontiev, A.N. (1964). *Probleme der Entwicklung des Psychischen*. Berlin: Verlag Volk und Wissen.
- Leydesdorff, L. (2004). Strong anticipation in social systems and the emergence of a knowledge-based society. <http://www.leydesdorff.net/emergence/>. Accessed 17 March 2010.
- Leydesdorff, L. (2008). The connection of meaning in anticipatory systems: a simulation study of the dynamics of intentionality in social interactions. In D. Dubois (Ed.), *Proceedings of the 8th International Conference on Computing Anticipatory Systems CASYS'07* (pp. 338–348), Melville: American Institute of Physics Conference Proceedings.
- Libet, B., Gleason, C.A., Wright, E.W., Pearl, D.K. (1983). Time of conscious intention to act in relation to onset of cerebral activity (readiness-potential). The unconscious initiation of a freely voluntary act. *Brain*, 106, 623–642.
- Louie, A.H. (2007). A living system must have noncomputable models. *Artificial Life*, 13, 293–297.

- Louie, A.H. (2008). Functional entailment and immanent causation in relational biology. *Axiomathes, Humanities, Social Science and Law Series* (pp. 289–302), Amsterdam: Springer Netherlands.
- Louie, A.H. (2009). *More than life itself: a synthetic continuation in relational biology*. Frankfurt: ontos Verlag.
- Mancuso, J.C., & Adams-Weber, J. 1982. Anticipation as a constructive process. In C. Mancuso, J. Adams-Weber (Ed.), *The construing person* (pp. 8–32). New York: Praeger.
- McCulloch, W.S., & Pitts, W.H. (1943). A logical calculus of the ideas immanent in nervous activity. *Bulletin of Mathematical Biophysics*, 5, 115–133.
- Melzer, I., Benjuya, N., Kaplanski, J. (2001). Age-related changes of postural control: effect of cognitive tasks. *Gerontology*, 47(4), 189–194.
- Mickulecky, D.C. (2007). Robert Rosen, his students and his and his colleagues: a glimpse into the past and the future as well. *Chemistry & Biodiversity*, 4(10), 2269–2271.
- Minch, E. (1986). A review of “ANTICIPATORY SYSTEMS” by Robert Rosen, Pergamon Press, Oxford, 1985, X + 436 *International Journal of General Systems* (pp. 405–409). Oxford: Taylor & Francis.
- MindRaces: from reactive to anticipatory cognitive embodied systems*. <http://www.mindraces.org/>. Accessed February 2009
- Mitchell, A., et al. (2009). Adaptive prediction of environmental changes by organisms. *Nature*, 460, 220–224. <http://www.nature.com/nature/journal/v460/n7252/full/nature08112.html>.
- Munduteguy, C., & Darses, F. (2007). Perception and anticipation of others' behaviour in a simulated car driving situation. *Travail Humain*, 70(1), 1–32.
- Myers, M.L. (2007). Anticipation of risks and benefits of emerging technologies: a prospective analysis method. *Human and Ecological Risk Assessment*, 13(5), 1042–1052.
- Nadin, M. (1959). *The complementarity of measurement and observation: Ivanov and Schrödinger*, award-winning paper submitted in a context of a competition on the subject of The Foundations of Physics, Bucharest.
- Nadin, M. (1972). *To live art: elements of meta-aesthetics* (in Romanian: *A Trai Arta*). Bucharest: Eminescu.
- Nadin, M. (1987). Writing is rewriting. *The American Journal of Semiotics*, 5(1), 115–133.
- Nadin, M. (1991). *Mind – anticipation and chaos* (milestones in thought and discovery). Stuttgart: Belser Presse.
- Nadin, M. (2000). Anticipation – a spooky computation. In D.M. Dubois (Ed.), *Proceedings of the Third Conference on Computing Anticipatory Systems CASYS'99* (pp. 3–47), New York: AIP Proceedings.
- Nadin, M. (2003). *Anticipation – the end is where we start from*. Basel: Müller Verlag.
- Nadin, M. (2004). *Project seneludens*. <http://seneludens.utdallas.edu>. Accessed 10 Apr 2009.
- Nadin, M. (2005). Anticipating extreme events – the need for faster-than-real-time models. In: V. Jentsch, S. Albeverio (Ed.), *Extreme Events in Nature and Society* (Frontiers Collection) (pp. 21–45). New York: Springer.
- Nadin, M. (2007). *Anticipation scope and anticipatory profile*. Project proposal submitted to the NIH.
- Nadin, M. (2009a). Anticipation comes of age. In M. Nadin (Ed.), *Journal of Risk and Decision Analysis* (pp. 73–74). Amsterdam: IOS.
- Nadin, M. 2009a. Anticipation and risk – from the inverse problem to reverse computation. In M. Nadin (Ed.), *Journal of Risk and Decision Analysis* (pp. 113–139), Amsterdam: IOS.
- Nadin, M. (2009b). Anticipating the digital university. In P. Kellenberger (Ed.), *Proceedings of the 2009 Third International Conference on Digital Society (ICDS 2009)*. Los Alamitos: IEEE Computer Society. <http://portal.acm.org/citation.cfm?id=1511488>. Accessed 27 April 2010.
- Nadin, M. (2009c). Anticipation and the artificial. Aesthetics, ethics, and synthetic life. <http://www.springerlink.com/content/k181860167682270/>. Accessed 15 December 2009. See also print edition: Special issue on *Ethics and Aesthetics of Technologies – AI & Society* (Computer Science) (pp. 103–118). London: Springer.

- Nadin, M. (2010a). Anticipation and dynamics. Rosen's anticipation in the perspective of time, with a special. In G. Klir (Ed.), *International Journal of General Systems* (pp. 3–33). London: Taylor & Francis.
- Nadin, M. (2010a). Annotated bibliography of texts concerning anticipatory systems/anticipation. In G. Klir (Ed.), *International Journal of General Systems* (pp. 34–133). London: Taylor & Francis.
- Nadin, M. (2010b). Anticipatory computing: from a high-level theory to hybrid computing implementations. In *International Journal of Applied Research on Information Technology and Computing* (IJARITAC) (pp. 1–27).
- Nadin, M. (2010c). Play's the thing. a Wager on healthy aging. In J.C. Bowers, C. Bowers (Ed.), *Serious Games* (pp. 150–177). Hershey: IGI (Global Disseminator of Knowledge).
- Nadin, M. (2010d). La ciencia del cambio (A Science of Change). In F. Chorda, *Vivir es Cambiar* (pp. 129–178), Barcelona: Anthropos.
- Nadin, M. (2011a). Rich evidence: anticipation research in progress, *International Journal of General Systems*, DOI:10.1080/03081079.2011.622087. Available Online First, 11 October 2011: <http://dx.doi.org/10.1080/03081079.2011.622087>.
- Nadin, M. (2011b). The anticipatory profile. An attempt to describe anticipation as process, *International Journal of General Systems*, DOI:10.1080/03081079.2011.622093. Available Online First, 11 October 2011: <http://dx.doi.org/10.1080/03081079.2011.622093>.
- Nadin, M. (2012a). Rich evidence: anticipation research in progress. In M. Nadin (Ed.), Special edition: Anticipation, *International Journal of General Systems*, 41(1), 1–3.
- Nadin, M. (2012b). The Anticipatory profile. An attempt to describe anticipation as process. In M. Nadin (Ed.), Special edition: Anticipation, *International Journal of General Systems*, 41(1), 43–75.
- Nadin, M. (2012c). Anticipation: a bridge between narration and innovation. In L. Becker and A. Mueller (Eds.), *Narrative + Innovation*. Wiesbaden: VS Verlag fur Sozialsissenschaften.
- von Neumann, J. (1951). General Logical Theory of Automata. In L.A. Jeffries (Ed.), *General Mechanisms of Behavior – The Hixon Symposium*, 5(9). New York: J. Wiley & Sons, 315.
- von Neumann, J. (1963). *The Collected Works*. In A.H. Taub (Ed.). New York: Macmillan, 5.
- Pattee, H.H. (2007). Laws, constraints and the modeling relation – history and interpretations. *Chemistry & Biodiversity*, 4, 2212–2295.
- Pelikan, P. (1964). Developpement du modèle de l'instinct de conservation (Development of the model of the self-preservation instinct). In: *Information Processing Machine*. Prague: Czechoslovak Academy of Sciences.
- Penrose, R. (1989). *The Emperor's new mind*. New York: Oxford University Press.
- Pezzulo, G., Falcone, R., Joachim Hoffmann, J. (2007a). Anticipation and anticipatory behavior. *Cognitive Processing*, 8(2), 67–70.
- Pezzulo, G., Falcone, R., Joachim Hoffmann, J. (2007b). Anticipation and anticipatory behavior: II. *Cognitive Processing*, 8(3), 149–150.
- Powers, W.T. (1973). *Behavior: the control of perception*. New York: Aldine de Gruyter.
- Powers, W.T. (1989). Living control systems: selected papers of William T. Powers, I. New Canaan: Benchmark.
- Powers, W.T. (1992). Living control systems, II: *selected papers of William T. Powers*, I. New Canaan: Benchmark.
- Pribam, K.H. (2000). Free will: The brain as an anticipatory system. In D.M. Dubois (Ed.), *Proceedings of the Third Conference on Computing Anticipatory Systems CASYS'99* (pp. 53–72), New York: AIP Proceedings.
- Rashevsky, N. (1954). Topology and life: in search of general mathematical principles in biology and sociology. *Bull. Math. Biophysics*, 16, 317–348.
- Riegler, A. (2001). The role of anticipation in cognition. In D.M. Dubois (Ed.), *Computing Anticipatory Systems* (pp. 534–541). Melville: AIP Proceedings.
- Riegler, A. (2004). Whose anticipations? In M. Butz, O. Sigaud, P. Gerard (Ed.), *Anticipatory behavior in adaptive learning systems: foundations, theories, and systems*. Lecture Notes in Artificial Intelligence (pp. 11–22). Dordrecht: Springer.

- Rosen, J. (2008). Private e-mail communication, August 8, prompted by a message from George Klir.
- Rosen, J., & Kineman, J.J. (2004). Anticipatory systems and time: a new look at Rosennean complexity. *Proceedings of the 48th Annual Conference of the International Society for the Systems Sciences*, Special Integration Group on What is Life/Living? Pacific Grove, CA: ISSS.
- Rosen, R. (1972). Planning, management, policies and strategies: four fuzzy concepts, 77–16. CSDI Lecture, 16 May. <http://www.rosen-enterprises.com/RobertRosen/RRPlanningManagementPoliciesStrategiesFourFuzzyConcepts.pdf>. Accessed 3 March 2009.
- Rosen, R. (1978). Fundamentals of measurement and representation on natural systems. *General Systems Research Series*. New York: Elsevier.
- Rosen, R. (1979). Anticipatory systems in retrospect and prospect. *General Systems Yearbook*, 24, 11–23.
- Rosen, R. (1985a). *Anticipatory systems. philosophical, mathematical and methodological foundations*. New York: Pergamon.
- Rosen, R. (1985b). Organisms as causal systems which are not mechanisms: an essay into the nature of complexity. In R. Rosen (Ed.), *Theoretical biology and complexity: three essays into the natural philosophy of complex systems* (pp. 165–203). Orlando: Academic.
- Rosen, R. (1985c). Letter to Professor L.A. Segel. Rehovot: The Weizmann Institute of Science.
- Rosen, R. (1991). *Life itself*. New York: Columbia University Press.
- Rosen, R. (2000). *Essays on life itself*. New York: Columbia University Press.
- Rosen, R. (2006a). Autobiographical reminiscences (with an Epilogue by Judith Rosen). *Axiomathes*, 16(1–2), 1–23.
- Rosen, R. (2006b). Autobiographical reminiscences. <http://www.rosen-enterprises.com/RobertRosen/rosenautobio.html>. Accessed 17 March 2009.
- Roth, G. (1978). The role of stimulus movement patterns in the prey catching behavior of *Hydromantes genii* (Amphibia, Plethodontidae). *Journal of Comparative Physiology A: Neuroethology, Sensory, Neural, and Behavioral Physiology*, 123(3), 261–264.
- Sahyoun, C., et al. (2004). Towards an understanding of gait control: brain activation during the anticipation, preparation and execution of foot movements. *Neuroimage*, 21(2), 568–575.
- Scheffer, M., Bascompte, J., Brock, W.A., Brovkin, V., Carpenter, S.R., Dakos, V., Held, H., Nes, E.H.v., Rietkerk, M., Sugihara, G. (2009). Early-warning signals for critical transitions. *Nature*, 461, 53–59.
- Schrödinger, E. (1944). *What is life?* Cambridge: Cambridge University Press.
- Segel, L. (1987). What is theoretical biology? *Nature*, 319, 457.
- Shackle, G.L.S. (1938). *Expectations, investment and income*. Oxford: Oxford University Press.
- Shackle, G.L.S. (1961). *Decision, order and time in human affairs*. New York: Cambridge University Press.
- Shannon, C.E. (1948). A mathematical theory of communication. *Bell System Technical Journal*, 27, 379–423 and 623–656.
- Shannon, C.E., & Weaver, W. (1949). *The mathematical theory of communication*, Urbana: University of Illinois Press.
- Staiger, T.O. (1990). *Biology's Einstein?* (unpublished manuscript).
- Steckner, C.A. (2001). Anatomy of anticipation. In D.M. Dubois (Ed.), *Proceedings of the Fourth International Conference on Computing Anticipatory Systems CASYS 2000* (pp. 638–651). New York: AIP Conference Proceedings.
- Svoboda, A. (1960). Un modèle d'instinct de conservation (A model of the self-preservation instinct). *Information Processing Machine* (pp. 147–155). Prague: Czechoslovak Academy of Sciences.
- Tsirigotis, G., et al. (2005). The anticipatory aspect in neural network control. *Elektronika ir Electrochika*, 2(58), 10–12.
- Vámos, T. (1987). Anticipatory systems by Robert Rosen, *Automatica*, 23(1), 128–129.
- Volpert, W. (1969). *Untersuchung über den Einsatz des mentalen Trainings beim Erwerb einer sensomotorischen Fertigkeit*. Doctoral dissertation, University of Cologne.
- Vygotsky, L.S. (1964) (originally written in 1934). *Denken und Sprechen*. Stuttgart: Fischer.

- Vygotsky, L., & Luria, A. (1970). Tool and symbol in child development. In J. Valsiner, R. van der Veer (Ed.), *The Vygotsky Reader*. <http://www.marxists.org/archive/vygotsky/works/1934/tool-symbol.htm>. Accessed 5 April 2010.
- Werbos, P. (2010). Mathematical foundations of prediction under complexity. Lecture presented at the Paul Erdős Lecture Series, University of Memphis. http://www.werbos.com/Neural/Erdos_talk_Werbos_final.pdf. Accessed 6 April 2010.
- Wigner, E.P. (1961). On the impossibility of self-replication. In *The Logic of Personal Knowledge* (p. 231), London: Kegan Paul.
- Wigner, E.P. (1982). The limitations of the validity of present-day physics. In *Mind in Nature, Nobel Conference XVII* (p. 119), San Francisco: Harper & Row.
- Wiener, N. (1948). *Cybernetics: or the control and communication in the animal and the machine*. Paris: Librairie Hermann & Cie, and Cambridge: MIT.
- Windelband, W. (1894). *Geschichte und Naturwissenschaft, Pra`ludien. Aufsätze und Reden zur Philosophie und ihrer Geschichte*. History and Natural Science. Speech of the Rector of the University of Straßburg), Tübingen: J. C. B. Mohr, pp. 136–160.
- Zadeh, L.A. (1978). Fuzzy sets as a basis for a theory of possibility. *Fuzzy Sets and Systems*, 1(1), 3–28.
- Zadeh, L.A. (1996). Fuzzy sets and information granularity. In G.J. Klir, B. Yuan (Ed.), *Advances in fuzzy systems – applications and theory, Vol 6. Fuzzy sets, fuzzy logic and fuzzy systems. selected papers by Lotfi A. Zadeh* (pp. 433–448), Singapore: World Scientific. This article was originally printed in Zadeh, L.A. (1979). (M. Gupta, R. Ragade, R. Yager (Ed.)), *Advances in fuzzy set theory and applications* (pp. 3–18). Amsterdam: North-Holland.
- Zadeh, L.A. (2001). A new direction in AI: toward a computational theory of perceptions. *AI Magazine*, 22(1), 73–84.
- Zadeh, L.A. (2003). Foreword, *anticipation – the end is where we start from* (pp. 1–3). Basel: Müller.
- Zadeh, L.A. (2009a). *From fuzzy logic to extended fuzzy logic – a first step*. Presentation made at the North American Fuzzy Information Processing Society (NAFIPS), Cincinnati, June 15.
- Zadeh, L.A., et al. (2009b). *Perception-based data mining and decision making in economics and finance*. Berlin: Springer.